



Series 959TA14

Twin Alternating Metered Water Softening System



Operation and Maintenance Manual

Table of Contents

System Specifications and Warnings	4
Introduction	5
Assembly and Installation Instructions	9
Plumbing Diagram	13
General Installation	14
Series 959 Control Valve Programming	15
User Information Displays	19
Volume Calculator	20
Parts Breakdown	23
Front Cover and Drive Assembly	25
Main Body Internal Parts	26
Injector Housing Assembly.....	27
Water Meter	28
Motorized Alternating Valve (MAV)	29
Brine Tank Assembly	30
System Specifications	31
Troubleshooting	33
Water Softener Log	40
Manufacturer’s Warranty	43

System Specifications and Warnings

System Specifications

Water pressure: 40 psi minimum 100 psi Maximum

Water Temperature: 40°F to 110°F

Electrical Requirements:

Supply Voltage: 120V

Supply Frequency: 60Hz

Output Voltage: 24V AC

Output Current: Maximum 3.0 Amps

Water Meter:

Pipe Size: 3"

Accuracy: ± 5%

Minimum Flow: 3.5 GPM

Control Valve to Tank Connection: 6" Flange

Control Valve Distributor Pipe Connection: 3"

Circuit Board Memory: NonVolatile EEPROM (**E**lectrical **E**rasable **P**rogrammable **R**ead **O**nly **M**emory)

Compatible with the following typical concentrations of regenerant chemicals: Sodium Chloride, Potassium Chloride, Potassium Permanganate, Sodium Bisulfite, Chlorine and Chloramines



Warnings

The control valve and fittings are not designed to support the weight of the system or the plumbing.

Do not use Vaseline, oils, other hydrocarbon lubricants or spray silicone anywhere. A silicone lubricant may be used on black o-rings.

Hydrocarbons such as kerosene, benzene, gasoline, etc., may damage products that contain o-rings or plastic components. Exposure to such hydrocarbons may cause the products to leak. Do not use the product(s) contained in this document on water supplies that contain hydrocarbons such as kerosene, benzene, gasoline, etc.

The water meter should not be used as the primary monitoring device for critical or health effect applications.

Do not use pipe dope or other sealants on threads. Teflon tape is recommended to be used on all threads. Use of pipe dope may break down the plastics in the control valve.

1. INTRODUCTION

Long term, successful operation of any water softening system depends upon the care and attention it receives. Ordinarily, water treatment systems will provide uniform performance after the initial start-up period and operation is stable. Gallonage delivery between regenerations and treated water purity usually do not vary appreciably over the life of the resins--as long as the mineral content of the incoming water does not change.

This manual is intended to be a practical reference guide for all operating personnel. In view of the fact that system performance can change very dramatically throughout the year, a discussion of "ion exchange" theory is included in addition to basic information relative to equipment operation and regeneration procedures. Thorough understanding of the simple chemical reactions will help to determine if some equipment malfunction has occurred, or if the system is simply responding to changing water conditions. For this reason, all operation and supervising personnel are encouraged to study Section 2, which define terminology and the simple chemistry associated with this system.

Ion exchange (i.e., the softening process) is a reversible reaction. Ion exchange softening resins have only a limited capacity for removing calcium and magnesium minerals. If the volume of water put through a resin bed exceeds its capacity, some hardness will start sloughing off into the treated water. Therefore, service runs must be terminated before this breakthrough occurs. When a run is over, the resins are treated with sodium chloride salt to displace the hardness and restore its removal capacity again. This process is termed "regeneration".

The degree of softening that can be accomplished depends upon several factors. The primary influences are the incoming water composition, type of resins used and amount of salt used. Secondary influences are the concentrations and flowrates at which NaCl is applied.

2. PRINCIPLES OF ION EXCHANGE IN THE SOFTENING PROCESS

2.1 ION EXCHANGE SOFTENING PROCESS

In order to understand what happens in the ion exchange softening process, it will first be necessary to understand the meaning of the terms which are used in the explanation. HARD WATER, CATION EXCHANGER, and BRINE are therefore defined below and then used to show how the ion exchange process works.

A. *Hard Water* - All natural waters contain much the same dissolved impurities, but in widely varying amounts. There are always enough ANIONS (-) present to balance the CATIONS (+), but anions have no effect on the ion exchange softening process. Water will be HARD, if it contains large amounts of Calcium (Ca++) and/or Magnesium (Mg++) ions.

B. *Brine* - water in which SALT has dissolved. SATURATED brine contains as much salt as it is possible to hold in solution (approx. 26% to 27%).

SALT - SODIUM CHLORIDE (NaCl). When dissolved in water it splits up (ionizes) into Sodium (Na+) ions and Chloride (Cl-).

SATURATED BRINE - contains a very great number of Na+ and Cl- ions (concentration is over 200,000 ppm). When used to regenerate a CATION EXCHANGER, only the Sodium ions (Na+) are put to use. The Chloride ions (Cl-) do not work in the process.

C. *Cation Exchanger* - a solid material which has a very large number of "REACTION POINTS". These reaction points have NEGATIVE (-) electric charges, and are able to attract and hold CATIONS, which are POSITIVELY (+) charged (much the same way as the way opposite poles of a magnet attract each other).

Introduction

- D. *The Softening Process* - When most of the reaction points have been occupied by Ca^{++} or Mg^{++} ions, hardness will begin to slip through the bed in increasing amounts. This rise in hardness in the effluent is an indication that the effective capacity of the CATION EXCHANGER has been reached. The CATION EXCHANGER must then be regenerated to restore it to its original condition.
- E. *Regeneration* - A solution of NaCl is applied to the CATION EXCHANGER at a controlled rate and the softening process is reversed. The Ca^{++} and Mg^{++} ions are driven off of the CATION EXCHANGER and replaced with Na^{+} ions. At the end of regeneration, the "spent" brine is rinsed away and the REGENERATED CATION EXCHANGER, with its reaction points again occupied by sodium ions -is again able to soften HARD WATER.

2.2 QUALITY OF EFFLUENT

If the hard water contains less than 500 ppm (about 30 grains) of Calcium, Magnesium and Sodium salts, all expressed as CaCO_3 , it will be found that the effluent from a softener will contain an average of not more than 2 ppm actual total hardness (Zero hardness by the SOAP TEST). However, as the total CATION concentration in the hard water increases above 500 ppm, the average hardness in the effluent will also increase proportionately.

The reason for this is that when the sodium salt - those present in the raw water plus those formed by the exchange reactions - are present in high enough concentrations, they cause a "back-regeneration" effect at the same time as the softening process is taking place. This effect prevents as complete a removal of calcium and magnesium as would otherwise be possible.

It is often possible to reduce the average hardness in the effluent below normally expected concentrations, by using a greater amount of salt than usual for regeneration.

Normal Softening Cycle - At the start of a normal softening cycle, the hardness in the effluent drops rapidly as the residue of hardness ions left in the bed at the end of the rinse are forced out. The effluent hardness reaches a certain minimum value and remains at approximately this concentration for the major part of the softening run.

2.3 CAPACITY OF ION EXCHANGER

The capacity for the removal of calcium and magnesium depends mainly upon the type of ion exchanger which is used. It is further influenced by the amounts of hardness and sodium ions in the raw water, and by the amount of salt used for regeneration.

- A. *Raw Water* - The effect of the amounts of hardness and sodium ions in the raw water, is expressed in terms of COMPENSATED HARDNESS. The hardness of the raw water is considered to be greater than it actually is for capacity determinations, whenever: (a) the total hardness is greater than 400 ppm (as CaCO_3), or (b) the sodium salts are over 100 ppm as (CaCO_3). This "greater-than-actual" hardness is referred to as COMPENSATED HARDNESS.
- B. *Salt Dosage* - The capacity which will be obtained from a cation exchanger is also determined by the amount of salt used during regeneration. The Kilograins (kgr) of hardness which can be removed by each cubic foot of ion exchanger between regenerations, increases as more salt is used for regeneration.

At the same time, the efficiency of salt usage decreases with the higher regenerant dosages. That is, a greater number of Kilograins of hardness are removed for each pound of salt used at the lower salt dosages, (and consequently, at the lower capacities). Thus, greater economy may be obtained at the expense of the number of gallons of water softened between regenerations.

3. NORMAL OPERATOR RESPONSIBILITIES

Long term, reliable system performance depends upon how conscientiously the equipment is operated and maintained. Operator responsibilities to assure operation should include the following recommended practices:

3.1 MAINTAIN OPERATING LOGS

Operators should maintain close control of the process by monitoring system performance daily. Effluent purity, hardness leakage, service run lengths and pressure drop across the bed must be recorded faithfully. Since resins are subject to fouling, decrease in product quality or run length could be the result of fouling. In addition to operating data, log notations should include chemical delivery dates, equipment design changes, or modifications in program settings. This information can be invaluable if troubleshooting is ever required.

The daily log should be updated once or twice a shift and should include the following information:

1. Date and Time
2. Which Softener is Online
3. Inlet and Outlet pressure gauge readings; calculated pressure drop
4. Influent hardness
5. Effluent hardness
6. Gallon capacity remaining
7. Record salt usage
8. Any equipment design changes, or modifications in programmed cycle settings or capacity settings

4. OPERATING & REGENERATION PROCEDURES

4.1 DESCRIPTION OF OPERATION

The system is designed for fully automatic operation. Each unit is equipped with a NHWBP (No Hard Water Bypass) valve that controls the In-Service and Standby modes. Service runs will automatically switch to the stand-by tank when the meter set point has been reached, initiating the regeneration cycle. The stand-by tank then becomes the service tank and the exhausted tank begins a regeneration cycle.

4.2 REGENERATION CYCLE

A. SERVICE

During service flow, raw water passes through the inlet of the control valve and downflow through the resin bed, through the lower hub and lateral distribution system, up the distributor pipe and exits through the outlet of the control valve and into the service lines. Service flow continues until the preset gallonage has been used, initiating the regeneration process.

B. BACKWASH

Raw water passes through the inlet of the control valve and is directed down through the distributor pipe to the bottom of the tank. Water flow passes through the lower hub and lateral distribution system and travels upflow through the resin bed. The water expands the bed scrubbing the resin beads and washing any entrapped dirt out through the control valve drain port and out to drain. Backwash sequence lasts approximately 10 minutes.

Introduction

- C. **BRINE AND SLOW RINSE**
Raw water is directed through the injector built into the main regeneration control. A venturi action in the injector draws the required amount of brine into the softener. The solution of salt water then passes downflow through the resin bed, through the lower hub and lateral distribution system, up the distributor pipe and exits through the drain port of the control valve and out to drain. The level of water in the brine tank should be drawn down from the preset level. The brine float air check valve shuts off air when the preset drawdown is reached. Raw water continues to the drain through the main control valve slow rinsing the resin for the remainder of the cycle. Brine and slow rinse sequence lasts approximately 60 minutes.
- D. **SECOND BACKWASH**
Water flow is the same as the first backwash. This step in the regeneration process helps to remove iron that was released from the resin during the Brine cycle. The second Backwash sequence lasts approximately 6 minutes.
- E. **FAST RINSE**
Raw water passes through the inlet of the control valve and downflow through the resin bed, through the lower hub and lateral distribution system, up the distributor pipe and exits through the drain port of the control valve and out to drain. This sequence removes all remaining brine from the resin bed. The Fast Rinse sequence lasts approximately 10 min.
- F. **BRINE REFILL**
When the regeneration cycle is finished, fresh water flows through the brine line and into the brine tank refilling it to the preset level. The brine valve float will control water makeup level.

A WORD OF CAUTION -- DON'T ARBITRARILY MAKE CHANGES, IF YOU WISH TO MAINTAIN EFFICIENT REGENERATIONS.

Assembly and Installation Instructions

Placement of Water Treatment Equipment

Locating the proper place for your water softener is important. Here are some important considerations before the placement of the system.

1. The unit should be located as close to the point of use of the treated water as is possible. Verify that the water pressure does not exceed 100 psi before installing the system. The water pressure of the system should range between 50 psi and 100 psi maximum. Damage may occur to the system and/or control valve if the pressure is allowed to exceed 100 psi and the manufacturer's warranty will be void.
2. The system must be provided with an open (gravity) drain of sufficient size to handle the maximum flow rate of waste-water (*See System Specifications for the flow rates*) without overflowing or splashing. The drain lines must not be smaller than the size of the drain port located on the control valve.
3. It is important that a clean power supply, that originates from a fused non-interruptible 120 V AC 60 cycle source, sufficient to operate the controller during normal operating conditions, is provided. *An electrical surge protector or UPS (Uninterruptible Power Source) is recommended.*
4. Do not place system in a location where particularly corrosive fumes are present or heavy equipment and/or traffic is present. (*However, the system is constructed to handle normal industrial atmospheric and vibrational conditions.*)
5. The system must be located on a sturdy, level floor. Otherwise a platform must be built that is capable of supporting the complete assembly including the weight of the water in the tanks.
6. The system should be installed within twenty feet of a suitable drain that is capable of handling the backwash requirements of the system.
7. **Some systems are quite large. Entrances to the desired location must be large enough to accommodate the size of the largest component of the system.** Also, there must be adequate space for the system before installation. (*For measurements of the system check the model spec sheet.*)
8. The system must be placed in a location where it will not freeze.

Loading the Mineral Tank with Media

Below is a list of instructions for loading the mineral tank with media:

1. Remove the disposable retainer plug in the top of the mineral tank. This retainer plug is used to secure the distributor assembly inside the tank and protect it from damage during shipping and handling.
2. Inspect the distributor assembly located at the bottom of the mineral tank before loading the media. Center the distributor in the bottom of the tank.

WARNING: DO NOT LOAD THE TANK IF THE DISTRIBUTOR APPEARS TO BE DAMAGED IN ANY WAY!

3. Place the mineral tank where you want to install the system.
 - Careful consideration of the proper position of the empty mineral tank is necessary since the system will be difficult to move once it is completely loaded.
4. Plug the top opening of the distributor pipe to keep any media from entering the pipe while loading the mineral tank. Fill the tank approximately 1/3 full of water. The water will aid as a cushion to protect the lower distributor assembly from gravel impact.

Note: The enclosed funnel has been added to aid the media installation.

5. Load the gravel into the mineral tank first. After the proper amount of gravel has been placed in the tank make sure the gravel bed is level so that distributor laterals are completely covered.
6. Load the water softening resin into the mineral tank. After loading the resin, fill the remainder of the mineral tank with water.

Note: Care should be taken when installing the gravel and resin that internal piping and tank lining is not damaged.

Mounting the Control Valves

1. Mount the flange adapter to the tank using the stainless steel, nut and bolt pack that was packaged with the flange adapter. It is recommended that an anti-seize lubricant be used on the threads of each bolt.
2. Push the flow disperser inside the flange adapter until it clips into the groove.
3. Grease the flange O-ring and the distributor pilot O-ring before mounting the control valve.

Caution: DO NOT USE PETROLEUM BASED GREASES!

4. Guide the distributor pipe into the distributor pilot.
5. Special precaution is advised to avoid pinching or damaging the flange O-ring.
6. Lower and adjust the control valve until it rests square and flush with the flange adapter.
7. Open the hinged clamp and fit over the flange adapter and control valve.
8. Close clamp and loosely attach the bolted clasp. This allows for proper alignment of the control valve for installation.
9. Once control valve is properly aligned, tighten bolted clasp.

Repeat above steps to mount the control valve on each tank.

The system is now ready to install.

Plumbing Diagram

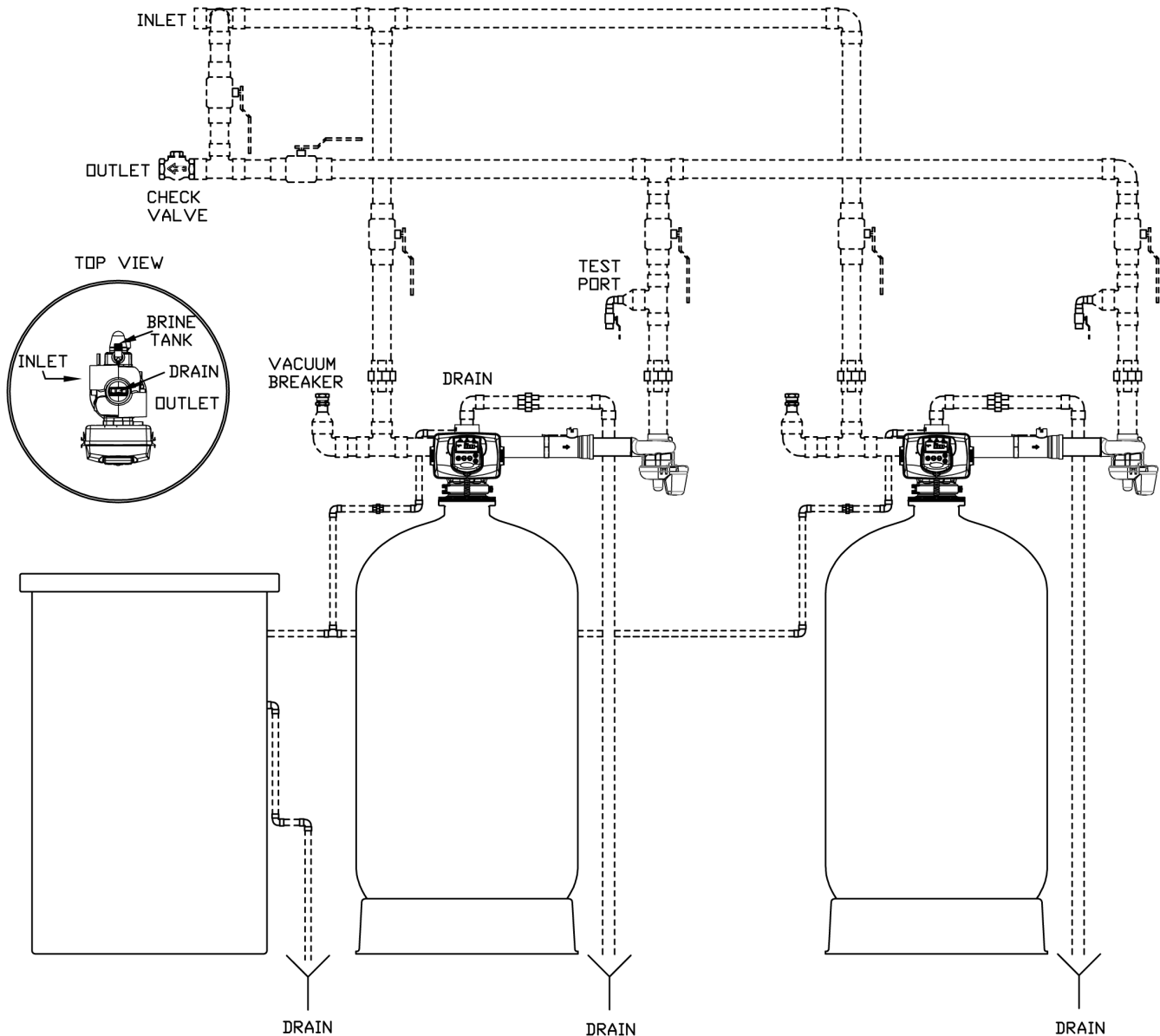

Plumbing Notes:

All plumbing should be done according to local plumbing codes. Dashed piping, fittings and valves supplied by others.

1. Unions must be installed to facilitate removal of the control valve for servicing.
2. This system uses tanks that must not be subjected to a vacuum. A vacuum breaker must be installed in an upright position per drawing.
3. Water meter must be installed in the horizontal position as shown in the drawing. Note directional arrow on meter casting.

Plumbing Connections

Note: All plumbing should be done in accordance with local plumbing codes.

Inlet and Outlet Connections:

Connect piping to unit using the Plumbing Diagram as a guide. Unions need to be installed in the inlet, outlet and drain piping to facilitate removal of the control valve for servicing.

Connect the incoming untreated water line to the inlet connection on the left side of the control valve and the outgoing treated water line to the outlet connection on the right side of the control valve. Inlet and outlet connections are marked with directional arrows.

Drain Connections

Do not solder joints near the Drain Line Flow Controller (DLFC). The DLFC has rubber components that could be damaged by heat. Soldering should be done prior to connecting to the DLFC fitting.

Connect drain line to the DLFC located on the top of the control valve, making sure the drain lines are properly supported and secured to prevent excessive vibration or strain. Make the drain line as short as possible, leaving an air gap to visibly monitor the water flow to the drain.

Option: Drain line may be run using Sch.80 PVC

Brine Tank

Make sure that the floor beneath the salt tank is both level and clean.

Connect the brine tubing from the brine tank to the control valve using the tubing and fittings, (packaged inside the brine tank.) Brine connection on the softener is located on the top rear of the control valve.

To prevent water damage in case of brine tank overflow, locate the overflow fitting on the outside of the brine tank directly below the fittings for the tubing. Attach tubing to the overflow fitting and position it so that the excess water flows to the drain.

If seismic straps are included secure to floor and brine tank.

Note: On very large systems the tubing and fittings are not included. The system requires hard piping to the brine tank such as Sch.80 PVC.

Pressure Testing

Verify water pressure is within operating range.

The unit should be pressure tested prior to the initial operation.

- To begin pressure test, slowly open the inlet water valve to the unit.
- Allow pressure build up to line pressure and observe for leaks.
- Correct as necessary.

Series 959 Control Valve Programming

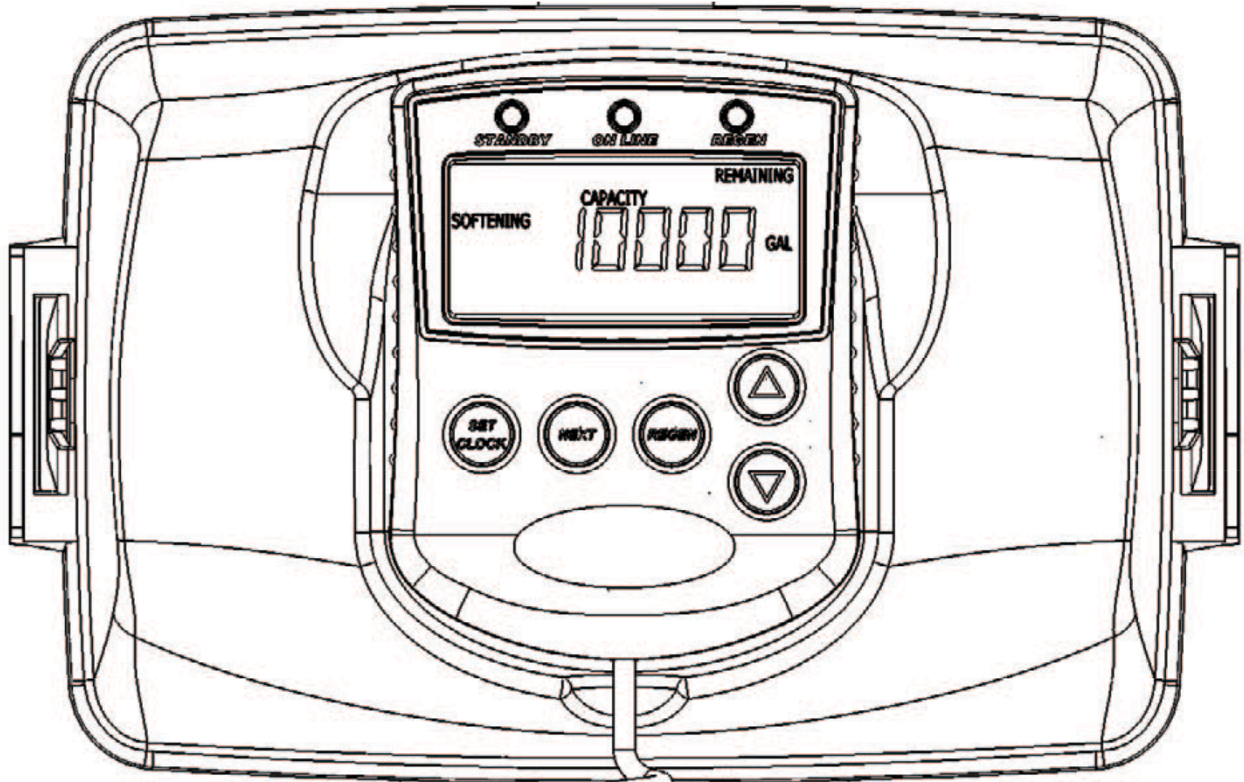

Control Valve Programming

Set the Clock

Press the **SET CLOCK** button. The hour digit will begin flashing. Use the **UP** and **DOWN** buttons to adjust the hour setting.

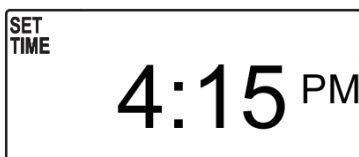

Press the **SET CLOCK** button again. The minutes will begin flashing. Use the **UP** and **DOWN** buttons to adjust the minutes setting.

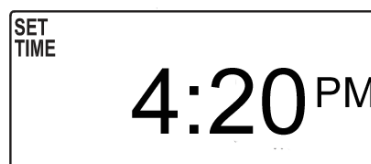

After the minutes and hour settings have been adjusted press **SET CLOCK** to complete setting the clock.

Set Gallons Between Regenerations

Before you can set the gallons between regenerations you will need to know the water softener capacity and the water hardness. For your convenience a gallon calculator has been provided on pages 20-22.

Note: To calculate the gallons between regenerations use the following formula.

Capacity multiplied by 0.8 divided by Hardness



To set gallons between regenerations press and hold **NEXT** and **UP** buttons simultaneously for approximately five seconds. The numbers will begin flashing. To adjust the gallons use the **UP** or **DOWN** buttons. Press **NEXT** to complete setting the gallons between regenerations and to advance to the **DAY OVERRIDE**.

Control Valve Programming

Day Override

This setting should be set to OFF. Twin systems do not require a day override.

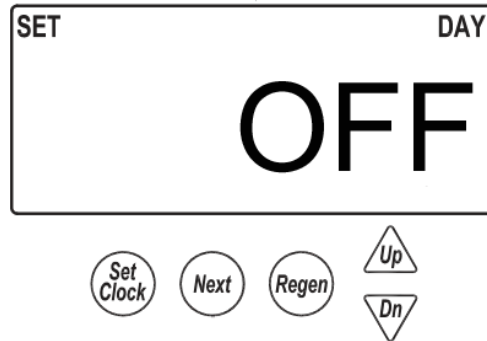

Press **NEXT** to advance to the Time of Regeneration

Time of Regeneration

The System regenerates when the volume remaining reaches 0. This setting is not adjustable.

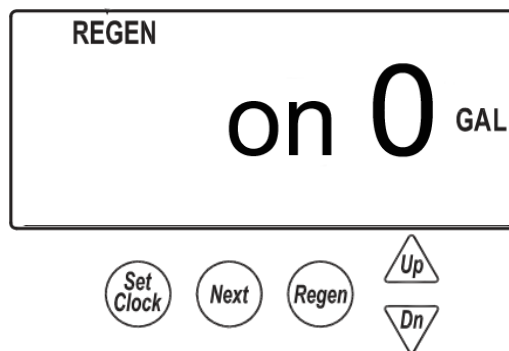

Press **NEXT** to exit programming.

User Information Displays

During normal operation one of three screens can be displayed. Pressing the **NEXT** button alternates between these displays.

1. **Current Time of Day**
2. **Current Flow Rate in Gallons per Minute**
3. **Totalizer (Total gallons used since installed)**
4. **Capacity Remaining in Gallons**

Adjustments **cannot** be made from the user information displays.

See Examples Below

Time of Day Display

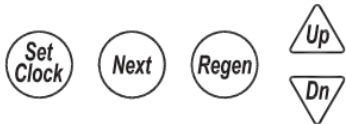
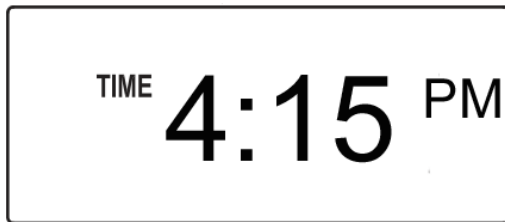

Current Flow Rate

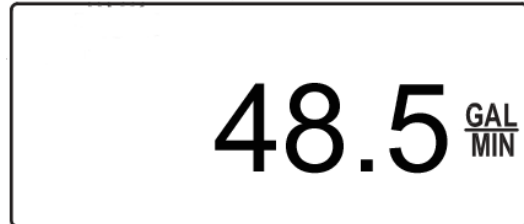

Totalizer

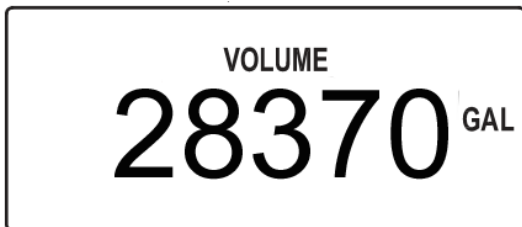

Capacity Remaining in Gallons



Volume Calculator

MODEL NUMBER	WATER HARDNESS 10-14				
	10	11	12	13	14
A959SM-300	24,000	21,500	20,000	18,000	17,000
A959SM-450	36,000	32,500	30,000	27,500	25,500
A959SM-600	48,000	43,500	40,000	36,500	34,000
A959SM-750	60,000	54,500	50,000	46,000	42,500
A959SM-900	72,000	65,000	60,000	55,000	51,000
A959SM-1050	84,000	76,000	70,000	64,500	60,000
A959SM-1200	96,000	87,000	80,000	73,500	68,500

MODEL NUMBER	WATER HARDNESS 15-19				
	15	16	17	18	19
A959SM-300	16,000	21,500	20,000	18,000	17,000
A959SM-450	36,000	32,500	30,000	27,500	25,500
A959SM-600	48,000	43,500	40,000	36,500	34,000
A959SM-750	60,000	54,500	50,000	46,000	42,500
A959SM-900	72,000	65,000	60,000	55,000	51,000
A959SM-1050	84,000	76,000	70,000	64,500	60,000
A959SM-1200	96,000	87,000	80,000	73,500	68,500

Volume Calculator

MODEL NUMBER	WATER HARDNESS 20-24				
	20	21	22	23	24
A959SM-300	12,000	11,000	10,500	10,000	9,500
A959SM-450	18,000	17,000	16,000	15,500	15,000
A959SM-600	24,000	22,500	21,500	20,500	20,000
A959SM-750	30,000	28,500	27,000	26,000	25,000
A959SM-900	36,000	34,000	32,500	31,000	30,000
A959SM-1050	42,000	40,000	38,000	36,500	35,000
A959SM-1200	48,000	45,500	43,500	41,500	40,000

MODEL NUMBER	WATER HARDNESS 25-29				
	25	26	27	28	29
A959SM-300	9,600	9,200	8,800	8,500	8,200
A959SM-450	14,000	13,500	13,000	12,500	12,000
A959SM-600	19,000	18,000	17,500	17,000	16,500
A959SM-750	24,000	23,000	22,000	21,000	20,500
A959SM-900	28,500	27,500	26,500	25,500	24,500
A959SM-1050	33,500	32,000	31,000	30,000	28,500
A959SM-1200	38,000	36,500	35,500	34,000	33,000

Volume Calculator

MODEL NUMBER	WATER HARDNESS 30-34				
	30	31	32	33	34
A959SM-300	8,000	7,700	7,500	7,200	7,000
A959SM-450	12,000	11,500	11,000	10,500	10,000
A959SM-600	16,000	15,000	14,500	14,000	13,500
A959SM-750	20,000	19,000	18,500	18,000	17,500
A959SM-900	24,000	23,000	22,500	21,500	21,000
A959SM-1050	28,000	27,000	26,000	25,000	24,500
A959SM-1200	32,000	30,500	30,000	29,000	28,000

MODEL NUMBER	WATER HARDNESS 34-39				
	35	36	37	38	39
A959SM-300	6,800	6,600	6,400	6,200	6,000
A959SM-450	10,000	9,800	9,600	9,400	9,200
A959SM-600	13,500	13,000	12,500	12,000	11,500
A959SM-750	17,000	16,500	16,000	15,500	15,000
A959SM-900	20,500	20,000	19,000	18,500	18,000
A959SM-1050	24,000	23,000	22,500	22,000	21,500
A959SM-1200	27,000	26,500	25,500	25,000	24,500

Parts Breakdown

Parts Breakdown

Front Cover and Drive Assembly

Drawing No.	Part No.	Description	Quantity
1	V3068	Pod Front and Back Covers	1
1a	V3082	Pod Assembly Complete with Circuit Board	1
2	V3241-01BOARD	Pod Circuit Board	1
3	V3248	Pod Cable	1
4	V3242-01BOARD	Valve Circuit Board	1
5	V3224-01R	Front Cover	1
6	V3107-01	Drive Motor Assembly	1
7	V3226-01	Drive Bracket Assembly	1
8	V3110	Drive Gear 12x36	3
9	V3109	Drive Gear Cover	1
10	N/A	This part does not apply to the single tank system	N/A
Not Shown	V3461	Power Cord (24 VAC Adapter)	1

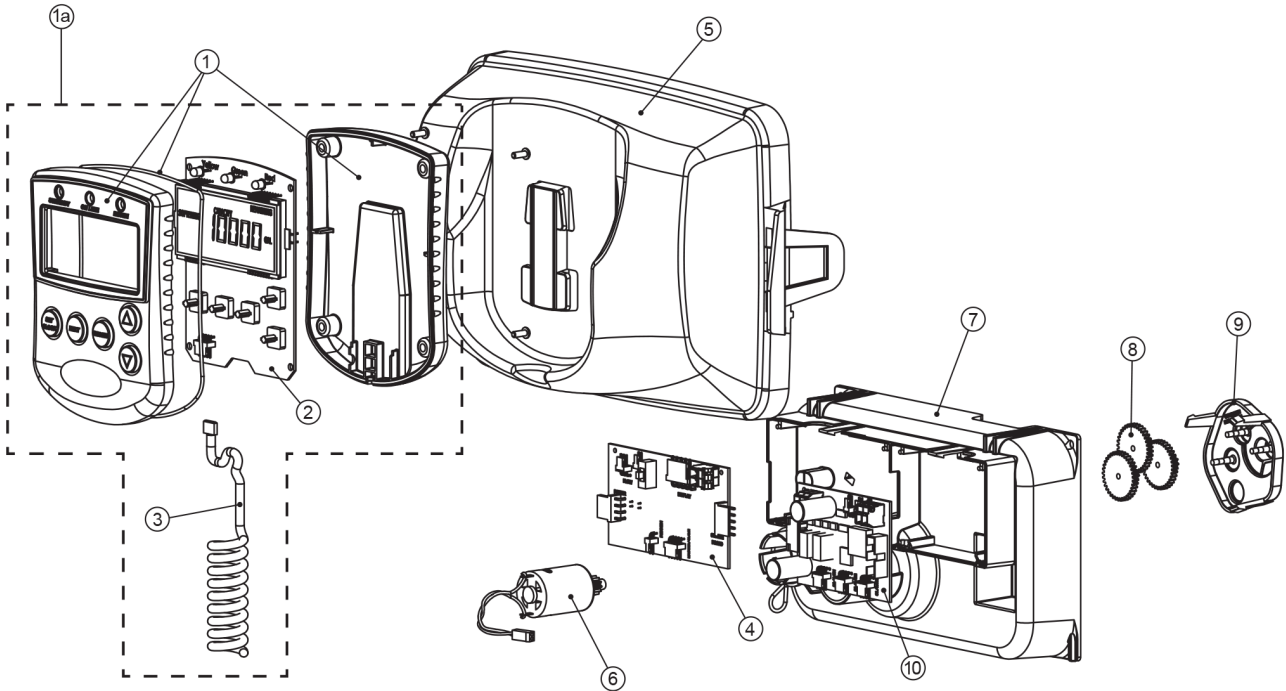

Parts Breakdown

Main Body Internal Parts

Drawing No.	Part No.	Description	Quantity
1	V3274	Drive Bracket Screw (SS 3/8-16x2)	4
2	V3291	Drive Bracket Washer (SS 3/8)	4
3	V3225	Back Plate	1
4	V3093	Drive Cap Assembly	1
5	V3289	Drive Cap O-Ring	1
6	V3666-01	Main Piston	1
7	V3238-01	Brine Piston	1
8	V3092	Seal and Spacer Stack Assembly	1
9	V3667-03	Valve Body	1
10	V3763	Valve Body O-Ring	1
11	V3762	Distributor O-Ring	1
12	V3091	Base Clamp Assembly	1
13	V3276	Clamp Bolt (SS 5/16-18x1.75)	1
14	V3269	Clamp Nut (SS 5/16-18)	1

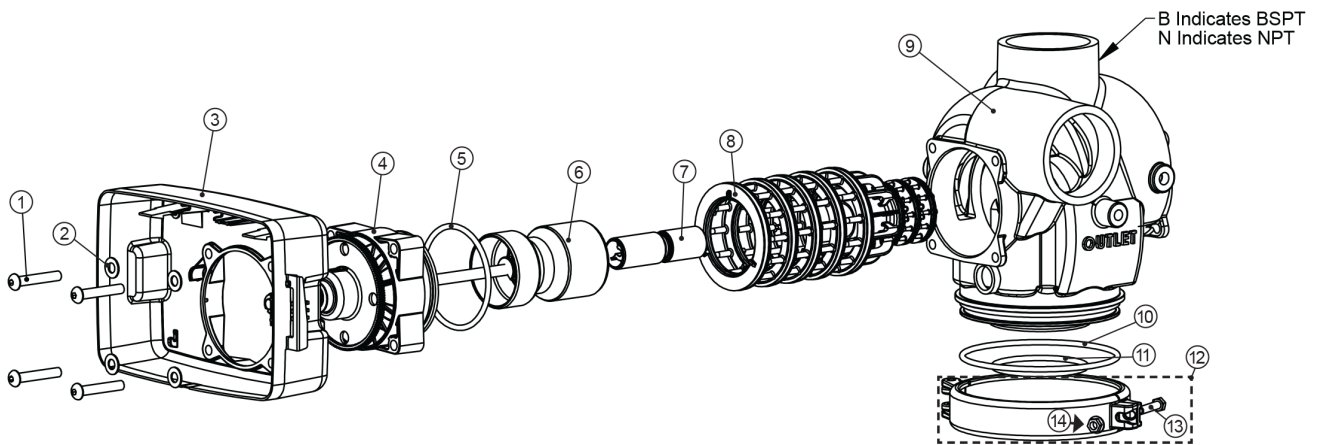

Parts Breakdown

Injector Housing Assembly

Drawing No.	Part No.	Description	Quantity
1	V3237-01	Soft Fill Tube Assembly	1
2	V3670-01	Injector Tube Down-flow Assembly	1
3	V3289	Injector Body O-Ring	1
4	V3067	Injector Body	1
5	V3477	Injector Cap	1
6	V3152	Injector Cap O-Ring	1
7	V3275	Injector Body Screw (SS 3/8-16x2.25)	4
8	V3291	Injector Body Washer Flat SS 3/8)	4
9	V3162-01	Brine Line Flow Control 1.0 GPM	1
10	V3231	Brine Refill Flow Control Retainer	1
11	V3277	Brine Refill Flow Control Retainer O-Ring	1
12	V3105	Brine Elbow O-Ring	1
13	V3150	Brine Elbow Split Ring	1
14	V3151	Brine Elbow Nut Quick Connect	1
15	V3149	Male NPT Elbow Fitting 1"	1
16	V3010-XX	Injector Assembly (Specify Size)	1

Proper orientation of Flow Control Button is important. Radius and text of button should be facing the Injector Body Assembly No. 3

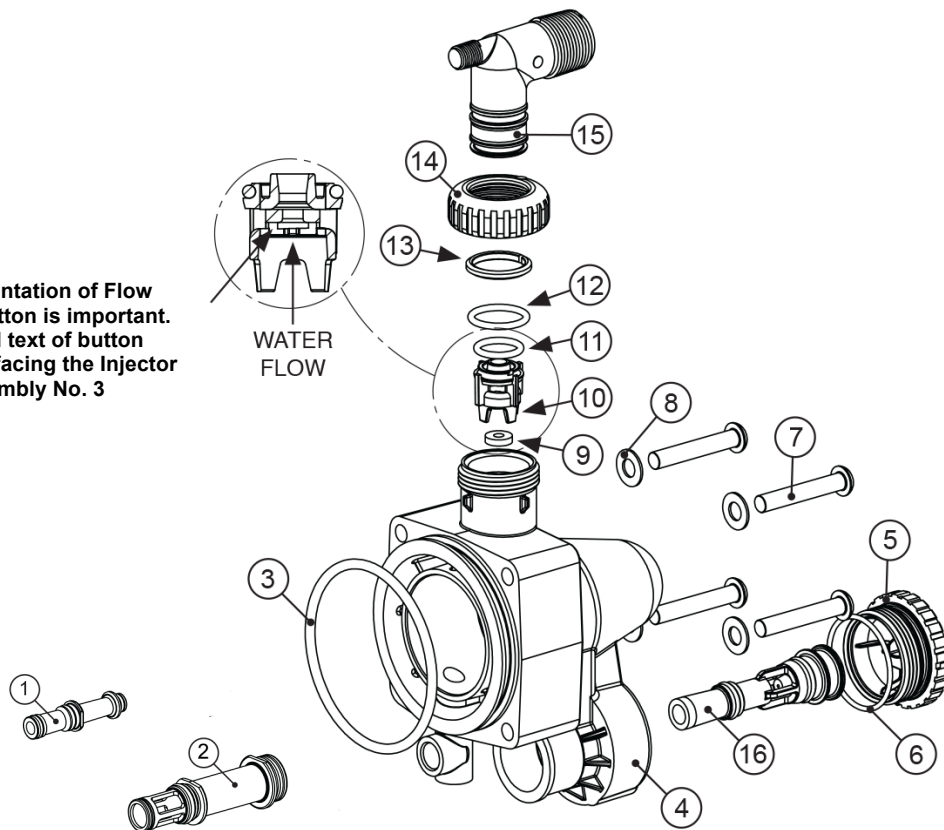

Parts Breakdown

Water Meter

Drawing No.	Part No.	Description	Quantity
1	V4039	Meter Assembly 4 Foot Cable (Includes parts 2,3, and 4)	1
	V3221	Meter Assembly 15 Foot Cable (Includes parts 2,3, and 4)	
5	V3844-01	3" Meter Body (Male X Female)	1
6	V3632	Meter Retaining Clip	1
Not Shown	V3602	Flow Straightener (Located inside meter housing)	1

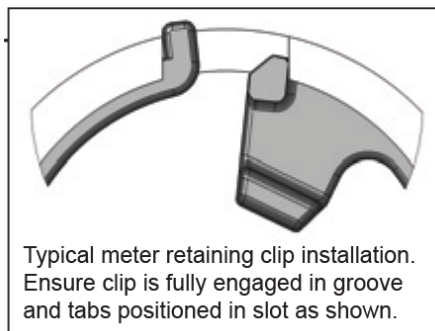
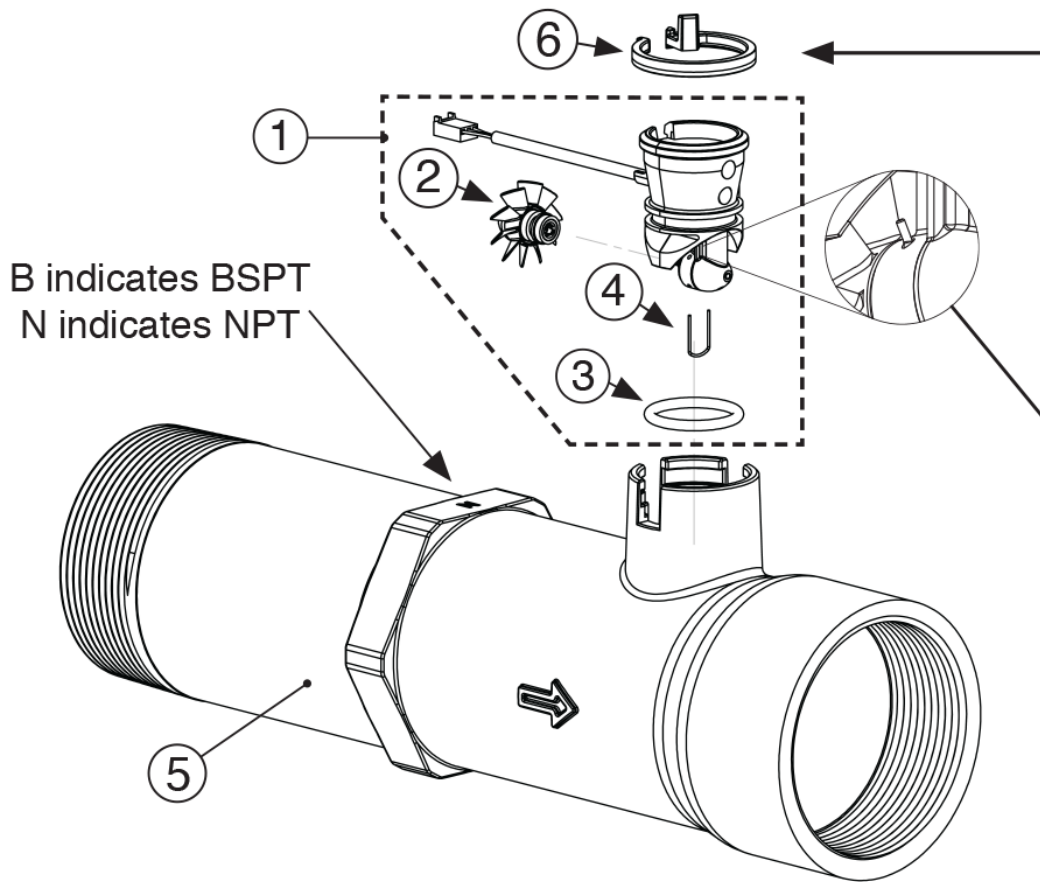

**Bend clip
after install**

Parts Breakdown

Motorized Alternating Valve (MAV)

Drawing No.	Part No.	Description	Quantity
1	V3606	MAV Cover Assembly	1
2	V3476	Motor Assembly 8ft. Cord	1
3	V3592	Reducing Gear Cover Screw	3
4	V3262-01	Reducing Gear Cover	1
5	V3110	Reducing Gear 12x36	3
6	V3264	Reduction Gear Axle	3
7	V3789	Drive Cap Screw	4
8	V3085	Drive Cap Assembly	1
9	V3695-01	Piston	1
10	V3084	Seal and Spacer Stack Assembly	1
11	V3693-01	Main Body	1

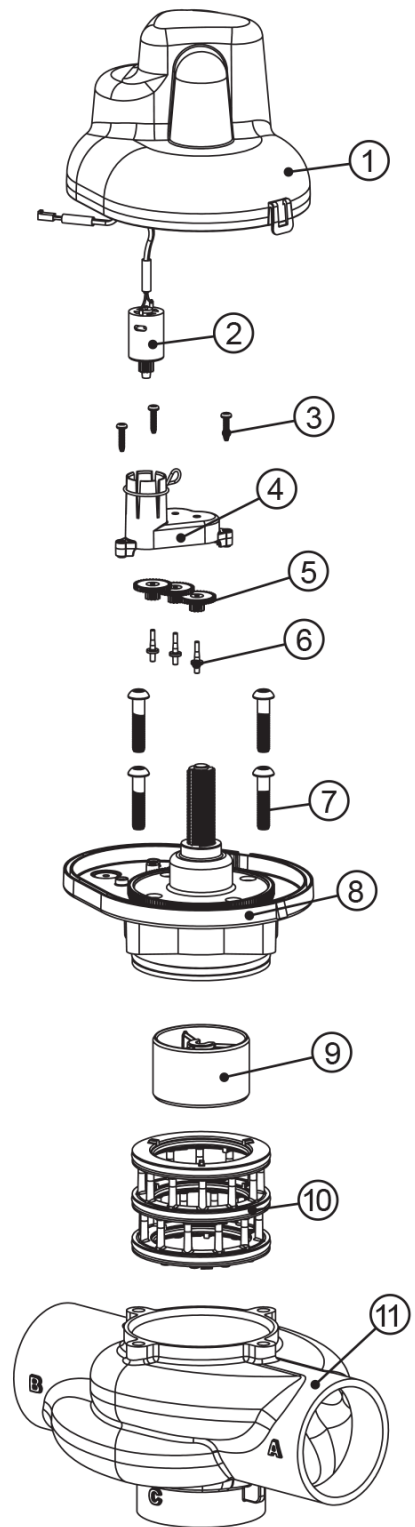

Parts Breakdown

Brine Tank Assembly

Drawing No.	Part No.	Description	Quantity
1	See System Specifications	Deck Assembly (Specify Height)	1
2	See System Specifications	Brine Tank (Specify Size)	1
3	HBWC-XX	6" Brine Well (Specify Length)	1
4	HBVA-454HF	454 Brine Valve Assembly Hi-Flow	1
5	HC-6	6" Brine Well Cap	1
6	HOF-C	Commercial Overflow Assembly	1



System Specifications

Mineral Tank Specifications

Grain Capacity	Mineral Tank	Gravel lbs.	Resin Cu/Ft	Distributor Assembly
300,000	24 x 72	150	10	DHLBA-24-3
450,000	30 x 72	250	15	DHLBA-30-3
600,000	36 x 72	450	20	DHLBA-36-3
750,000	42 x 72	700	25	DHLBA-42-3
900,000	42 x 72	700	30	DHLBA-42-3
1,050,000	48 x 72	1000	35	DHLBA-48-3
1,200,000	48 x 72	1000	40	DHLBA-48-3

Brine Tank Specifications

Grain Capacity	Brine Tank	Deck Height (in.)	Brine Float Valve	Brine Well
300,000	30 x 50	13	HBVA-454HF	HBWC-45
450,000	39 x 48	15	HBVA-454HF	HBWC-45
600,000	39 x 60	19	HBVA-454HF	HBWC-55
750,000	39 x 60	23	HBVA-454HF	HBWC-55
900,000	42 x 60	23	HBVA-454HF	HBWC-55
1,050,000	42 x 60	20	HBVA-454HF	HBWC-55
1,200,000	50 x 60	23	HBVA-454HF	HBWC-55

Control Valve Specifications

Grain Capacity	Injector Size	Drain Line Flow Control GPM	Brine Line Flow Control GPM	Brine Refill Time Min.
300,000	C	12	3.2	11 min
450,000	D	20	3.2	16 min
600,000	E	30	3.2	21 min
750,000	F	35	3.2	26 min
900,000	F	35	3.2	32 min
1,050,000	G	45	3.2	37 min
1,200,000	G	45	3.2	42 min

Troubleshooting the Control Valve

Control Valve Troubleshooting

Problem	Possible Cause	Solution
No display on Control Valve POD	No power at electrical outlet	Repair outlet or use working outlet
	Control valve power adapter not plugged into outlet or power cord end not connected to Circuit Board connection	Make sure Control Valve Power Cord is connected securely at both ends
	Improper power supply	Verify proper voltage is being delivered to Circuit Board
	Poor connection between POD connector and Circuit Board	Check connector on POD, possible broken wire or terminal pin not inserted properly in connector. Clean pins on Circuit Board by plugging and unplugging the POD connector a few times to remove excess protective coating.
	Defective power adapter	Replace power adapter
	Defective Circuit Board	Replace Circuit Board
POD Circuit Board does not display correct time of day	Control Valve Power Cord plugged into electric outlet controlled by light switch	Use uninterrupted outlet
	Tripped Breaker Switch and/or tripped GFI	Reset Breaker Switch and/ or GFI switch
	Power outage	Reset time of day.
	Defective Circuit Board	Replace Circuit Board
Display does not indicate that water is flowing. The word "Softening" flashes on the display when water is being used	Bypass valve in bypass position	Turn Bypass Handles to place Bypass in service position
	Meter is not connected to meter connection on Circuit Board or is not connected securely	Connect Meter to three-pin connection labeled FLOW on Circuit Board. Remove and reconnect to ensure proper connection
	Restricted/ stalled Meter Turbine	Remove Meter and check for rotation or foreign material
	Defective Meter	Replace Meter
	Defective Circuit Board	Replace Circuit Board
Time of day flashes on and off	Power outage	Reset time of day. If Circuit Board has battery back up present, the Battery may be depleted. Replace if necessary.
Control valve does not regenerate automatically when the REGEN button is depressed and held.	Broken Drive Gear or Drive Cap Assembly	Replace Drive Gear or Drive Cap Assembly
	Broken Piston Rod	Replace Piston Rod
	Defective Circuit Board	Defective Circuit Board
Control valve does not regenerate automatically but does when the REGEN button is depressed and held.	Bypass Valve in bypass position	Turn Bypass Handles to place Bypass in service position
	Meter is not connected to meter connection on Circuit Board or is not connected securely	Connect Meter to three-pin connection labeled FLOW on Circuit Board. Remove and reconnect to ensure proper connection
	Restricted/ stalled Meter Turbine	Remove Meter and check for rotation or foreign material
	Incorrect programming	Check for programming error
	Defective Meter	Replace Meter
	Defective Circuit Board	Replace Circuit Board

Control Valve Troubleshooting

Problem	Possible Cause	Solution
Hard or untreated water is being delivered	Bypass Valve is open or faulty	Fully close Bypass Valve or replace. Also check for multiple bypasses
	Media is exhausted due to high water usage	Check program settings or diagnostics for abnormal water usage
	Meter not registering	Remove Meter and check for rotation or foreign material
	Water quality fluctuation	Test water and adjust program values accordingly
	No Salt or low level of Salt in Brine Tank	Add proper type of salt to Brine Tank
	Control Valve fails to draw in brine	Refer to Troubleshooting Problem: <i>Control Valve fails to draw brine</i>
	Insufficient brine level in Brine Tank	Check refill setting in programming. Check Refill Flow Control for restrictions or debris and clean or replace
	Damaged Seal and Spacer Stack Assembly	Replace Seal and Spacer Stack Assembly
	Control valve body type and piston type mix matched	Verify proper control valve body type and piston type match
	Fouled media bed	Replace media bed
System uses too much salt	Improper setting for brine refill	Check brine refill setting
	Improper program settings	Check program setting to make sure they are specific to the water quality and application needs
	Control valve regenerates frequently	Check for leaking fixtures that may be exhausting capacity or system is undersized
	Slow drip from brine refill tubing. Float Valve is not designed to shut off a drip	Replace Seal and Spacer Stack Assembly
Residual salt in service lines	Low water pressure	Check incoming water pressure. Water pressure must remain at minimum of 40 psi
	Plugged or incorrect injector size	Replace Injector with correct size for the application. Refer to System Specification for the correct size
	Restricted drain line	Check drain line for restrictions or debris and clean
	Damaged Seal and Spacer Stack Assembly	Check Seal and Spacer stack assembly and piston. Replace as necessary
	Draw Time too short	Program proper draw time
	Excess Water in Salt Tank	Program proper brine refill time
	Vacuum Leak in Brine Connections or Brine Line	Locate vacuum leak and fix
Excessive water in Brine Tank	Improper program settings	Check refill setting
	Plugged Injector	Remove Injector and clean or replace
	Damaged Seal and Spacer Stack Assembly	Replace Seal and Spacer Stack Assembly
	Restricted or kinked drain line	Check drain line for restrictions or debris and or un-kink drain line
	Plugged backwash flow controller	Remove backwash flow controller and clean or replace
	Missing Refill Flow Controller	Replace Refill Flow Controller

Control Valve Troubleshooting

Problem	Possible Cause	Solution
Control Valve fails to draw brine	Injector is plugged	Remove Injector and clean or replace
	Faulty Brine Piston	Replace Brine Piston
	Brine line tubing connection leak	Inspect Tubing and Fittings for air leak
	Drain line restriction or debris can cause excess back pressure on Injector	Inspect drain line and clean to correct restriction
	Drain line too long or elevated too high	Shorten length and or height
	Low water pressure	Check incoming water pressure. Water pressure must remain at minimum of 40 psi
	Damaged Seal and Spacer Stack Assy.	Replace Seal and Spacer Stack Assy.
Water running to drain	Power outage during regeneration or unit is currently in regeneration	Upon power being restored Control Valve will finish the remaining regeneration time. Reset time of day.
	Damaged Seal and Spacer Stack Assembly	Replace Seal and Spacer Stack Assembly
	Piston assembly failure	Replace Piston Assembly
	Drive Cap Assembly not tightened in properly	Re-tighten the Drive Cap Assembly
Err - 1001 = Control unable to sense motor movement	Motor not inserted full to engage pinion, motor wires broken or disconnected	Disconnect power, make sure motor is fully engaged, check for broken wires, make sure two pin connector on motor is connected to the two pin connection on the Circuit Board labeled MOTOR. Press NEXT and REGEN buttons at the same time for 3 seconds to resynchronize software with piston.
	Circuit Board not properly snapped into drive bracket	Properly snap Circuit Board into drive bracket and then Press NEXT and REGEN buttons at the same time for 3 seconds to resynchronize software with piston.
	Missing reduction gears	Replace missing gears
Err - 1002 = Control valve motor ran too short and was unable to find the next cycle position and stalled	Foreign material is lodged in control valve	Open up Control Valve and pull out piston assembly and Seal and Spacer Stack Assembly for inspection. Press NEXT and REGEN buttons at the same time for 3 seconds to resynchronize software with piston.
	Mechanical binding	Check Piston and Seal and Spacer Stack Assembly, check Reduction Gears, check Drive Bracket and Main Drive Gear Interface. Press NEXT and REGEN buttons at the same time for 3 seconds to resynchronize software with piston.
	Main Drive Gear too tight	Loosen Main Drive Gear. Press NEXT and REGEN buttons at the same time for 3 seconds to resynchronize software with piston.
	Improper voltage being delivered to Circuit Board	Verify that proper voltage is being supplied. Press NEXT and REGEN buttons at the same time for 3 seconds to resynchronize software with piston.

Control Valve Troubleshooting

Problem	Possible Cause	Solution
Err - 1003 = Control valve motor ran too long and was unable to find the next cycle position	Motor failure during a regeneration	Check motor connections then Press NEXT and REGEN buttons at the same time for 3 seconds to resynchronize software with piston.
	Foreign matter built up on Piston and Seal and Spacer Stack Assemblies creating friction and drag enough to time out Motor	Replace Piston and Seal and Spacer Stack Assemblies. Press NEXT and REGEN buttons at the same time for 3 seconds to resynchronize software with piston.
	Drive Bracket not snapped in properly and out enough that reduction gears and drive gear do not interface	Snap Drive Bracket in properly then Press NEXT and REGEN buttons at the same time for 3 seconds to resynchronize software with piston.
Err- 14001= Message Queue Full	Master Circuit Board did not receive a response from the slave units	Press NEXT and REGEN buttons at the same time for 3 seconds to resynchronize software with piston.
Err- 15003= MAV or NHWBP ran too long and unable to find the proper position	Control Valve programmed for ALT A or NHWBP without having a motorized drive securely connected to the two pin terminal labeled BYPASS on the main Circuit Board	Press NEXT and REGEN buttons at the same time for 3 seconds to resynchronize software with piston position. Then reprogram valve to proper setting.
	Poor wire connection	Remove power and check connection for MAV or NHWBP motor to Circuit Board two pin connection labeled BYPASS. Make sure wires in connector are inserted securely and no wires are broken. Clean pins on Circuit Board by plugging and unplugging the connector a few times to removed excess coating. Press NEXT and REGEN buttons at the same time for 3 seconds to resynchronize software with piston.
	Excess drag causing timeout before stall	Open MAV or NHWBP to check for obstructions.
	MAV or NHWBP motor not fully engaged with reduction gears	Properly insert motor into casing, do not force into casing. Press NEXT and REGEN buttons at the same time for 3 seconds to resynchronize software with piston.
Err- 15010 or 15011= MAV or NHWBP Valve Motor ran too short (stalled) while trying to drive offline	Foreign material is lodged in MAV or NHWBP Valve	Open MAV or NHWBP and check for foreign material. Press NEXT and REGEN buttons at the same time for 3 seconds to resynchronize software with piston.
	Mechanical Binding	Check drive assembly piston, seal and spacer stack assembly, reduction gears, drive gear interface, and black drive pinion on drive motor. Press NEXT and REGEN buttons at the same time for 3 seconds to resynchronize software with piston.

Control Valve Troubleshooting

Problem	Possible Cause	Solution
<p>Number of Units Error Communications have been broken with the unit specified in the error message. 16001= Error with Unit 2 16002= Error with Unit 3 16003= Error with Unit 4 16004= Error with Unit 5 16005= Error with Unit 6</p>	<p>System is programmed for the wrong number of units or a slave unit is the "error number of units" mode due to loss of power.</p>	<p>Correct all errors on slave units before attempting to reset error on master.</p> <p>Pressing any button while in the "number of units error" will enter the user into the settings screen. Adjust to the correct units for the system and press NEXT to exit the setup screen.</p> <p>Press NEXT and REGEN buttons at the same time for 3 seconds to resynchronize software with piston. Reprogram valve to proper setting.</p>
	<p>Poor connection on the circuit boards.</p>	<p>Make sure wires in connector are inserted securely and now wires are broken.</p> <p>Clean pins on circuit board by plugging and unplugging the connector a few times</p> <p>Press NEXT and REGEN buttons at the same time for 3 seconds to resynchronize software with piston.</p>
	<p>More than one unit has determined that it is the master control.</p>	<p>Press NEXT and REGEN buttons at the same time for 3 seconds to resynchronize software with piston.</p> <p>Reprogram each valve to operate as a single unit.</p> <p>Reprogram the control that is to be the master control and it will filter down the programming to the slave controls automatically.</p>

Water Softener Log Sheet

It is important to keep a log of the water softener programming and other important information. This is necessary for repairs and other troubleshooting needs.

Date	Time	Hardness	Volume Remaining	Salt Usage	Pressure

Water Softener Log Sheet

It is important to keep a log of the water softener programming and other important information. This is necessary for repairs and other troubleshooting needs.

Date	Time	Hardness	Volume Remaining	Salt Usage	Pressure

Manufacturer's Limited Warranty

Pacific Water Inc. ("Manufacturer") warrants to the original owner that its Water Conditioning Equipment will be free from defects in material and workmanship under normal use and service for a period of five (5) years from the date of installation, when installed and operated within recommended parameters. No warranty is made with respect to defects not reported to Manufacturer within the warranty period and/or defects or damages due to neglect, misuse, alterations, accident, misapplication, physical damage, or damage caused by fire, floods, acts of God, freezing or hot water or similar causes. Manufacturer's obligation to the owner of this equipment under this Limited Warranty shall be limited, at its option, to replacement or repair of this Water Conditioning Equipment.

To obtain warranty service mail or ship the defective parts freight prepaid to the Manufacturer's place of business. Manufacturer will, at its option, repair or replace the defective components at its expense and return parts freight collect.

Manufacturer gives this warranty to the owner in lieu of all other warranties, express or implied, including without limitation any implied warranties of merchantability or fitness for a particular purpose and hereby expressly disclaims all other such warranties. Manufacturer's liability hereunder shall not exceed the cost of the product. Under no circumstances will Manufacturer be liable for any incidental or consequential damages or for any other loss, damage or expense of any kind, including loss of profits, arising in connection with the installation or use or inability to use this product.

To obtain warranty service contact:

Pacific Water Inc.
200 W. Haven Ave.
Salt Lake City, Utah 84115

Phone 801-485-6510
Fax 801-467-4117
Email sales@pacificwaterinc.com

