

SENTRY II™

Series 970

Electronic On-Demand Metered System



Service Manual

TABLE OF CONTENTS

	Page
General Warnings	3
Installation	5
Programming	7
System Start-Up	8
Frequently Asked Questions	10
Drawings and Part Numbers	11
Front Cover and Drive Assembly Breakdown	12
Internal Parts Breakdown	13
Injector Assembly Breakdown	14
Brine Elbow Assembly Breakdown	15
3/4" Drain Fitting Breakdown	16
1" Drain Fitting Breakdown	17
Meter Assembly Breakdown	18
Installation Fitting Assemblies	19
Bypass Assembly Breakdown	20
Bypass Valve Operation	21
Trouble Shooting Procedures	22

General Warnings

1. The control valve, fittings and/or bypass are designed to accommodate minor plumbing misalignments but are not designed to support the weight of a system or the plumbing.
2. Do not use Vaseline, oils, other hydrocarbon lubricants or spray silicone anywhere. A silicon lubricant may be used on black o-rings but is not necessary. **Avoid any type of lubricants, including silicone, on red or clear lip seals.**
3. The nuts and caps are designed to be unscrewed or tightened by hand or with the special plastic wrench. If necessary pliers can be used to unscrew the nut or cap. Do not use a pipe wrench to tighten or loosen nuts or caps. Do not place screwdriver in slots on caps and/or tap with a hammer.
4. Do not use pipe dope or other sealants on threads. Teflon tape must be used on the threads of the 1" NPT elbow or the 1/4" NPT connection and on the threads for the drain line connection. Teflon tape is not necessary on the nut connection or caps because of o-ring seals.
5. After completing any valve maintenance involving the drive assembly or the drive cap assembly and pistons, press and hold NEXT and REGEN buttons for 3 seconds or unplug power source jack from the printed circuit board (black wire) and plug back in. This resets the electronics and establishes the service piston position. The display should flash all wording, then flash the software version (e.g. 154) and then reset the valve to the service position.
6. All plumbing should be done in accordance with local plumbing codes. The pipe size for the drain line should be a minimum of 1/2". Backwash flow rates in excess of 7 gpm or length in excess of 20' require 3/4" drain line.
7. Solder joints near the drain must be done prior to connecting the drain line flow control fitting. Leave at least 6" between the drain line control fitting and solder joints when soldering pipes that are connected on the drain line control fitting. Failure to do this could cause interior damage to the drain line flow control fitting.
8. When assembling the installation fitting package (inlet and outlet), connect the fitting to the plumbing system first and then attach the nut, split ring and o-ring. Heat from soldering or solvent cements may damage the nut, split ring or o-ring. Solder joints should be cool and solvent cements should be set before installing the nut, split ring and o-ring. Avoid getting primer and solvent cement on any part of the o-rings, split rings, bypass valve or control valve.
9. Plug into an electrical outlet. Note: All electrical connections must be connected according to local codes. (Be certain the outlet is uninterrupted.)
10. Install grounding strap on metal pipes.

Table 1
System Specifications

Minimum/Maximum Operating Pressures	20 psi (138 kPa) -125 psi (862 kPa)
Minimum/Maximum Operating Temperatures	40°F (4°C) -110°F (38°C)
Current Draw & Voltage	0.5 Amperes 110 Volts Other options available

Pre-Installation Checklist

1. A standard electrical outlet (120V/60Hz) must be located within 12' of the installation site.
2. A functioning floor drain, washer standpipe or suitable location for waste water discharge must be located within 20' of the installation site. (see General Warning #6 on page 4)
3. A working pressure reducing valve must be installed on the inlet water line that supplies the water softener. **Note: The warranty is void if the system is exposed to water pressure in excess of 100 psi.**
4. The temperature at the location of the water softener system must never be below 40°F.

Installation

1. **Floor space:** Make sure the floor space that has been selected to install the water softener is clean and on a level surface.
2. **Leveling the salt container:** If the floor beneath the salt container is not level, do not use shims or spacers to level the salt container. A platform that supports the entire bottom surface of the salt container **must** be used.
3. **What to bypass:** A typical installation would include bypassing the outside hose bibs. The cold water feeding the kitchen sink may or may not be bypassed depending upon preference.
4. **Connection kit:** The standard connection kit supplied with the water softener will be a 3/4" brass sweat connection kit (see Figure 1). Other connection kits are available. (see Page 19)

This kit will consist of the following:

- 2 - Plastic nut 1" quick connect, black (#1)
- 2 - Plastic split ring, white (#2)
- 2 - O-Ring (#3)
- 2 - Brass connector 3/4" sweat (#4)

Figure 1

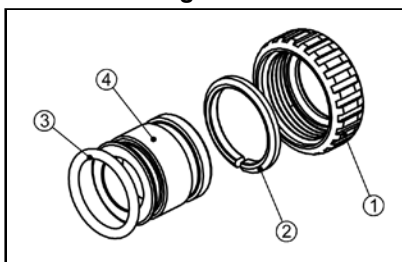

5. **Plumbing preparation:** Un-screw the two plastic nuts (#1) and pull on the two brass connectors (#4) to remove them from the bypass assembly. Next remove the white plastic split rings (#2) and the O-Rings (#3).
6. Solder at least 6" of pipe to the brass connectors before re-assembly. (see Figure 2)

Figure 2

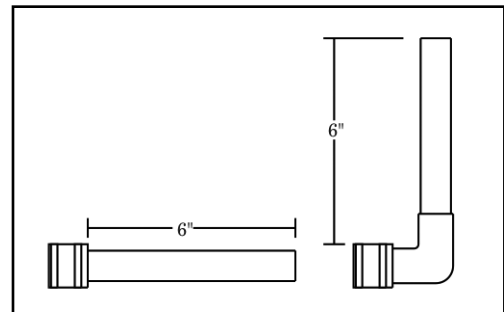

7. After soldering is complete, cool the pipe and connectors. Slide the plastic nuts (#1) over the brass connectors (#4). Place the white plastic split rings (#2) into the grooves closest to the copper pipe. Next place the O-Rings (#3) into the grooves closest to the end of the brass connectors (#4). Re-assemble the completed connection kit onto the bypass assembly. (see General Warning #8 on page 4)
8. **Plumbing:** When connecting the water softener to the existing plumbing, make sure the inlet water is connected to the inlet of the softener. Arrows on the valve body indicate direction of flow. Make sure the bypass valves are in the position shown in figure 3.

Figure 3

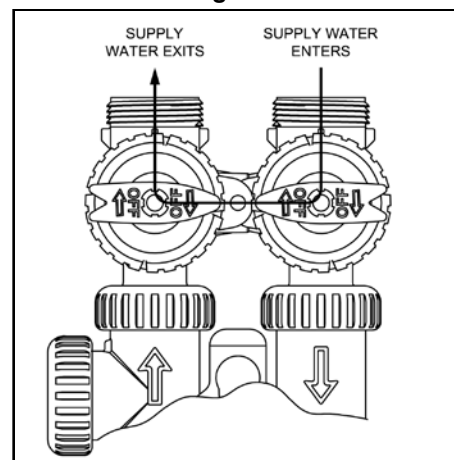

9. All plumbing should be done in accordance with local plumbing codes. (see General Warning #1 on page 4)

Installation

10. **Temporary Drain Tube:** Now that the water softener is connected to the existing plumbing, the drain line may be connected. First, disconnect the temporary piece of drain tubing and remove the polytube insert (#2) from the inside of the temporary drain tubing. Discard the temporary drain tubing.
11. **Connecting the drain line:** Slide plastic nut (#3) over the permanent drain tubing and place the polytube insert (#2) into the end of the drain tubing. Insert the drain tubing into the drain elbow fitting (#4) and tighten plastic nut (#3) handtight plus 1/2 turn with pliers. **Caution: Do Not Overtighten.** (see Figure 4)

Figure 4

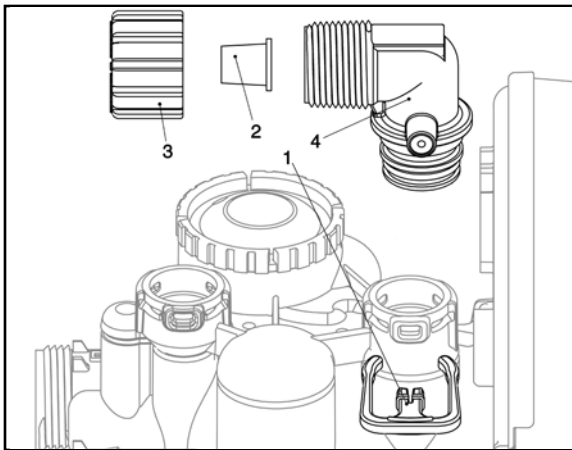

12. **Drain Line Specs:** If the distance from the water softener to the drain is greater than 20' the drain line size must be increased to 3/4". The threads on the drain elbow fitting are 3/4" male NPT and can be used in lieu of the 1/2" plastic nut and insert. If the drain line must run overhead, the maximum height of the drain line should not exceed 8' above the top of the water softener.
13. **Air Gap:** The drain line must have an approved air gap to prevent the possibility of a cross connection to the sewer. (see Figure 5)

Figure 5

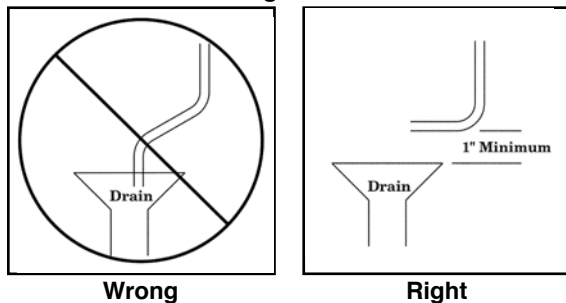

14. **Connecting the overflow line:** The brine overflow fitting is located on the outside of the salt container approximately 12" down from the top. Connect 1/2" drain tubing to the overflow fitting and run it to the nearest floor drain. This line is a gravity flow line and cannot be run overhead or cannot connect to a drain that is higher than the overflow fitting.
15. **Connecting the brine line:** A 3/8" brine line approximately 4' long is attached to the salt container and is supplied with the tube insert (#2) in the end of the brine line. (see Figure 6) Unscrew the brine nut (#3) and slide it over the end of the brine line. Insert the brine line into the brine ftg. (#4) and tighten the brine nut (#3) hand tight plus 1/2 turn with pliers. **Caution: Do Not Overtighten.**

Figure 6

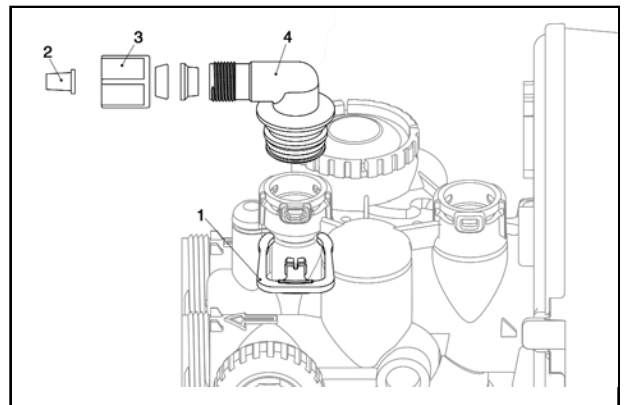

16. The water softener is equipped with a 15 foot power cord with built-in transformer. Plug the power cord into a standard (120V 60Hz) electrical outlet. It will take approximately 10 seconds before you will see the display (this is normal). The water softener is now ready to be programmed.

Programming the Controller

1. **Setting the Clock:** When the controller is first plugged in, the time of day display will be flashing.

Step 1: Press the **SET CLOCK** button.

Step 1

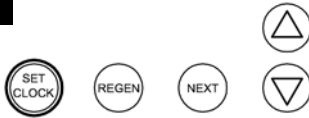

Step 2: The hour display will now be flashing. Set the correct hour by pressing either the Δ or the ∇ arrow button. The AM/PM indicator will toggle after the hour reaches 12. Press the **NEXT** button.

Step 2



Step 3: The minute display will now be flashing. Set the correct minutes by pressing either the Δ or the ∇ arrow button. Press the **NEXT** button. The display will no longer be flashing.

Step 3

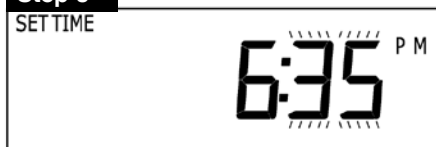

2. **Setting the Water Hardness, Day Override and regeneration times:**

Step 1: Press and hold the **NEXT** button and the Δ button at the same time for approximately 2 seconds to access hardness setting.

Step 1



Step 2 Setting the Hardness: The “SET HARDNESS” display will now be flashing. Set the correct raw water hardness by pressing either the Δ or the ∇ arrow button. If you do not know the water hardness for your location, contact your water treatment representative for this information. Press the **NEXT** button.

Step 2

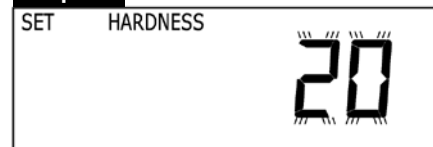

Step 3 Setting the Day Override: The “SET REGEN DAY” display will now be flashing. This setting is used to force a regeneration after a pre-set number of days has passed regardless of water usage. This setting can be adjusted by pressing either the Δ or the ∇ arrow button. This feature may be turned off by setting the display to less than 1. The default setting for this option is 15. Press the **NEXT** button.

Step 3



Step 4 Setting the time of regeneration:

The hour display will now be flashing. Set the correct hour by pressing either the Δ or the ∇ arrow button. The AM/PM indicator will toggle after the hour reaches 12. The default setting for this option is 2:00 AM. Press the **NEXT** button.

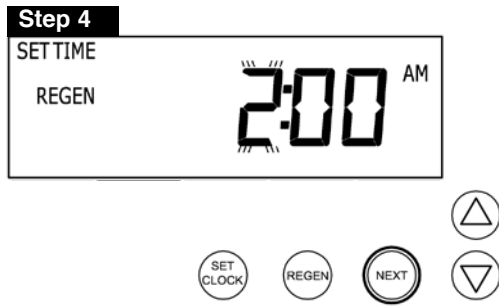

Step 5: The minute display will now be flashing. Set the correct minutes by pressing either the Δ or the ∇ arrow button. Press the **NEXT** button to exit the programming.

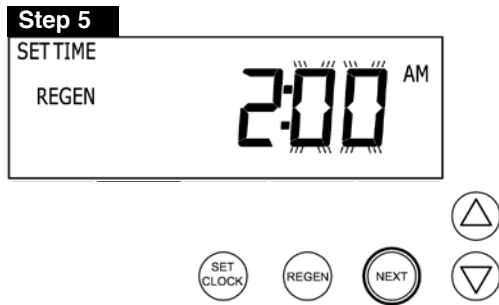

The display will no longer be flashing and programming is complete.

Notes:

1. When the system is operating, one of two displays will be shown, the current time of day or the capacity remaining. Pressing the **NEXT** button will alternate between the displays.
2. If the system has called for a regeneration that will occur at the preset time of regeneration, the words **REGEN TODAY** will appear on the display.
3. When water is being treated (i.e. water is flowing through the system) the word "Softening" flashes on the display.

Start -Up Instructions

1. **Adding Water to Salt Container:** Manually fill the salt container with fresh water until there is approximately 1" of water above the platform located in the bottom of the salt container.
2. **Manually Cycling the Controller:**

Step 1: Initiate a manual regeneration by pressing and holding the **REGEN** button until you hear the drive motor turn on (approx. 6 sec.). The "BACKWASH" display will flash until the motor stops running. The controller is now in the backwash cycle.



Step 2: Slowly open the red inlet bypass handle by turning it counter clockwise. The handles should now be in the same position as in Figure 1 (Bypass handles may be slightly difficult to turn.)

Figure 1

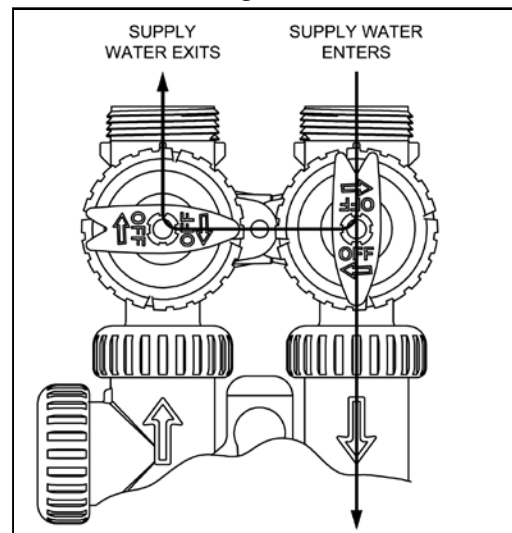

Discolored water and air will begin to run out of the drain hose (this is normal). Leave the controller in this position until the water coming out of the drain hose is clear.

Step 3: Press the **REGEN** button. The drive motor will run and the “BRINE” display will flash until the drive motor stops.



Step 4: Press the **REGEN** button. The drive motor will run and the 2nd “BACKWASH” display will flash until the drive motor stops.



Step 5: Press the **REGEN** button. The drive motor will run and the “RINSE” display will flash until the drive motor stops.



Step 6: Fill the salt container with extra coarse water softener salt. The amount of salt placed in the salt container at this time is not critical; however a minimum of 100 lbs. is recommended.

Note: Some of the values in the various display examples in this manual may not match the actual values of your controller.

Step 7: If the controller has not already moved to the “FILL” cycle, press the **REGEN** button. The drive motor will run and the FILL display will flash until the drive motor stops.



Leave the controller in this cycle for approx. 60 seconds to purge the air out of the brine valve.

Step 8: Press the **REGEN** button. The drive motor will run and the “SOFTENING” display will flash until the drive motor stops.

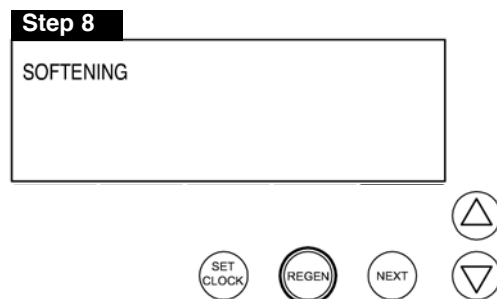

Once the drive motor stops, the manual regeneration is complete and the display will return to the normal display.

Step 9: Slowly open the red outlet bypass handle by turning it counter clockwise. The handles should now be in the same position as in Figure 2 (Bypass handles may be slightly difficult to turn.) The water softener is now ready for use.

Figure 2

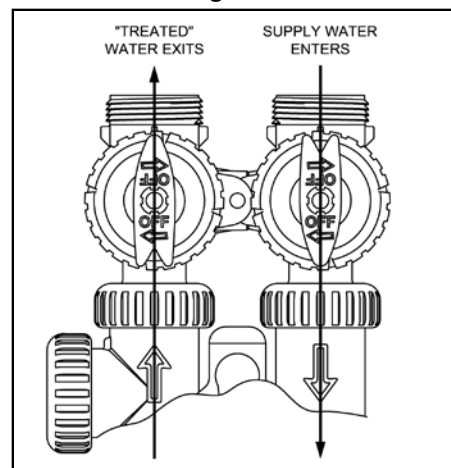

Frequently Asked Questions

Frequently Asked Questions

1. Question:

What type of salt can I use in this softener?

Answer:

The water softener will accept any type of salt made for water softeners; however, extra coarse rock salt is recommended.

2. Question:

How full can the salt container be filled with salt?

Answer:

Do not fill the salt container more than 6" from the top. The amount of salt maintained in the salt container is not critical, as long as you maintain salt above the water level. When looking inside of the salt container, you should always see dry salt. If you can see water in the bottom of the salt container, the salt level is too low.

3. Question:

Will it damage the water softener if it runs out of salt?

Answer:

Allowing the water softener to run out of salt will not damage the water softener in any way; however, if there is no salt in the salt container when a regeneration occurs, the system will cycle as normal but you will no longer be using softened water.

4. Question:

If the water softener has run out of salt, are there any special instructions before refilling the salt container with salt?

Answer:

Before refilling the salt container with salt, the water level must not be more than 1" above the platform in the bottom of the salt container. If there is more than 1" of water above the platform, bail the excess water out of the salt container until there is only 1" above the platform.

After refilling the salt container with salt, do not manually initiate a regeneration for at least 8 hours. The salt needs to sit in the water for the 8 hours to become completely saturated.

5. Question:

How often does the salt tank need to be cleaned?

Answer:

Dirt, rocks and debris collect in the bottom of the salt container (a little in each bag of salt). Therefore it is recommended that the salt tank should be cleaned approximately once a year. Allowing the salt tank to run low on salt will make this job a little easier.

6. Question:

Why do I want the water softener to regenerate at 2:00 AM?

Answer:

The water softener can regenerate at any time of the day or night. The purpose of regenerating during the night is to decrease the chance of water usage during the regeneration cycle.

7. Question:

Can I use water if the water softener is cycling?

Answer:

Yes, however any water used during the cycle will be hard water. If hot water is used during a cycle, it will add hard water into the water heater and mix with the softened water making the water in the water heater partially hard.

8. Question:

Why are the words "REGEN TODAY" on the display?

Answer:

If the system has called for a regeneration that will occur at the preset time of regeneration, the words **REGEN TODAY** will appear on the display.

9. Question:

Why does the word "SOFTENING" flash on the display?

Answer:

When water is being treated (i.e. water is flowing through the system) the word "Softening" flashes on the display.

DRAWINGS AND PART NUMBERS

Front Cover and Drive Assembly Breakdown

Drawing No.	Order No.	Description	Quantity
1	V3381-01EG	WS1ER Front Cover Assembly Black/Gold	1
	V3381-01ES	WS1ER Front Cover Assembly Black/Silver	
2	V3107-01	WS1 Motor	1
3	V3106-01	WS1 Drive Bracket & Spring Clip	1
4	V3491ER	WS1/1.25/1.5/2L ER PC Board	1
5	V3110	WS1 Drive Gear 12x36	3
6	V3109	WS1 Drive Gear Cover	1
Not Shown	V3186	WS1 AC ADAPTER 110V-12V	1
	V3186EU	WS1 AC ADAPTER 220-240V-12V EU	
	V3186UK	WS1 AC ADAPTER 220-240V-12V UK	
	V3186-01	WS1 AC ADAPTER CORD ONLY	

Relay Specifications: To insure proper fit and correct operation the following relay and relay socket manufactured by Idec or the exact equivalent should be used.

Idec Model and Description	
Relay Socket	SH3B-05C 3 pole finger safe rail mount socket
Relay	RH2LB-U-AC12V 12vac, DPDT magnetic latching relay

The relay supplies 2 sets of dry contacts for user applications. The wiring of these contacts is application specific.

Wiring For Correct On/Off Operation	
PC Board Relay Terminal Block	Relay Socket
SET	#13
COM	#12 and #14
RES	#9

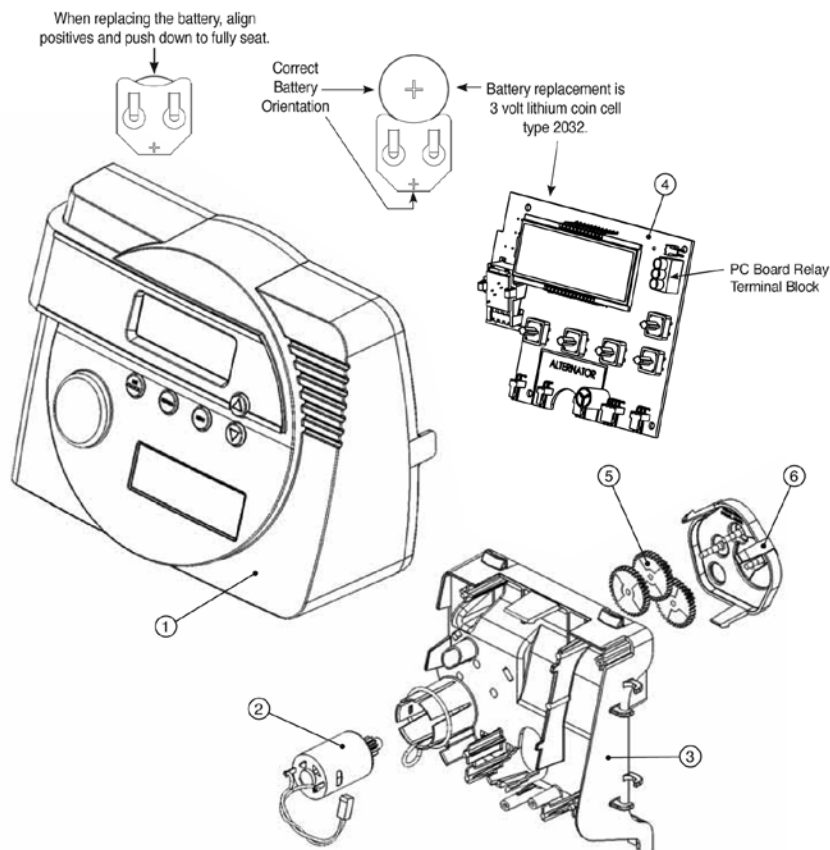

Drawing No.	Order No.	Description	Quantity
1	V3005	WS1 Spacer Stack Assembly	1
2	V3004	Drive Cap Assembly	1
3	V3382	WS1ER Drive Back Plate	1
4	V3011	WS1 Piston Assembly Downflow	1
5	V3174	WS1 Regenerant Piston	1
6	V3135	O-Ring 228	1
7	V3180	O-Ring 337	1
8	V3105	O-Ring 215 (Distributor Tube)	1
9	V3001	WS1 Body Assembly Downflow	1

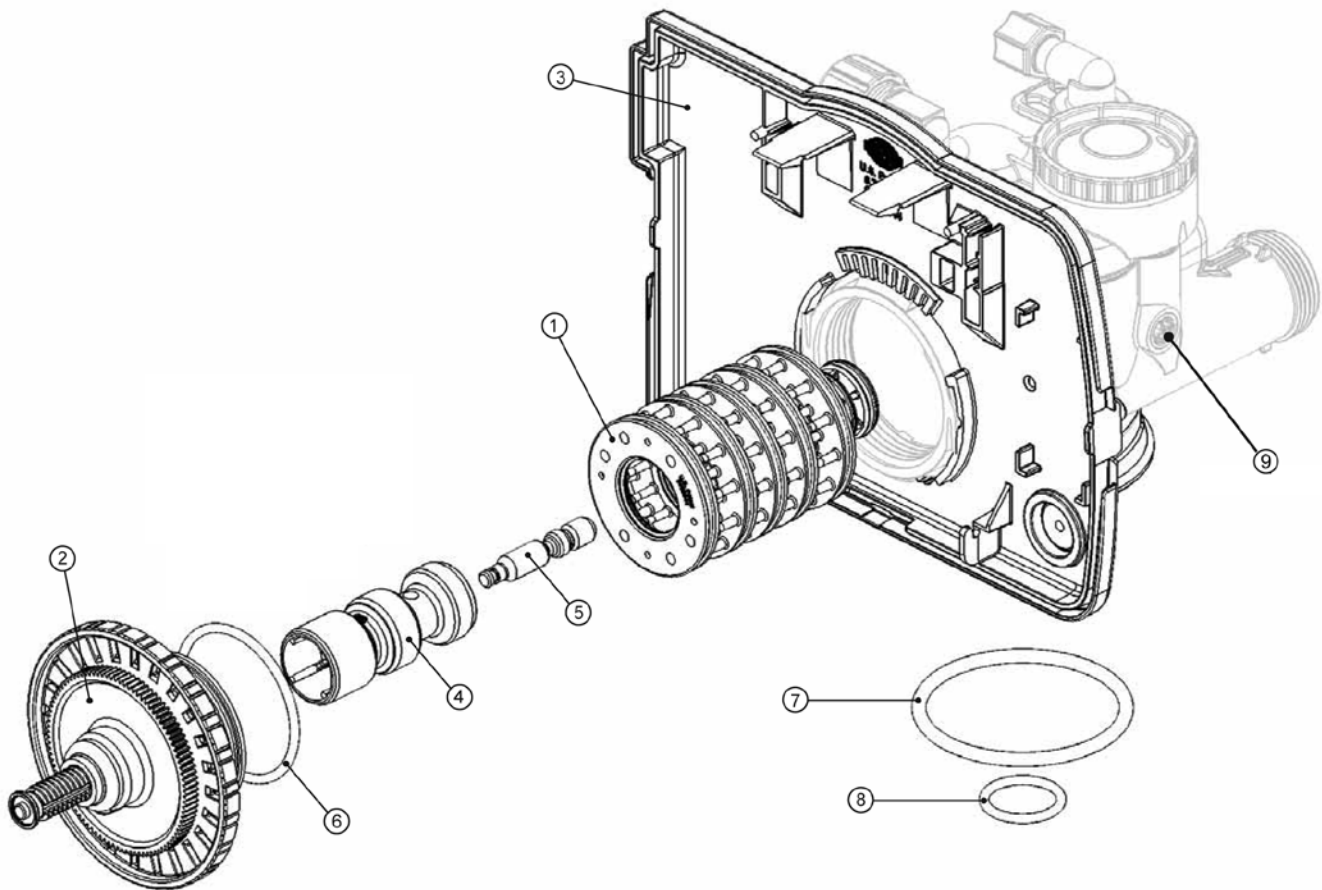

Injector Assembly Breakdown

Drawing No.	Order No.	Description	Quantity
1	V3176	Injector Cap	1
2	V3152	O-ring 135	1
3	V3177	Injector Screen	1
4	V3010-1Z	WS1 Injector ASY Z Plug	1
5	V3010-1A	WS1 INJECTOR ASY A BLACK	1
	V3010-1B	WS1 INJECTOR ASY B BROWN	
	V3010-1C	WS1 INJECTOR ASY C VIOLET	
	V3010-1D	WS1 INJECTOR ASY D RED	
	V3010-1E	WS1 INJECTOR ASY E WHITE	
	V3010-1F	WS1 INJECTOR ASY F BLUE	
	V3010-1G	WS1 INJECTOR ASY G YELLOW	
	V3010-1H	WS1 INJECTOR ASY H GREEN	
	V3010-1I	WS1 INJECTOR ASY I ORANGE	
	V3010-1J	WS1 INJECTOR ASY J LIGHT BLUE	
	V3010-1K	WS1 INJECTOR ASY K LIGHT GREEN	
Not Shown	V3170	O-ring 011	*
Not Shown	V3171	O-ring 013	*

*The injector plug and the injector each contain one 011 (lower) and 013 (upper) o-ring.

Note: For upflow position, injector is located in the up hole and injector plug in the down hole. For a filter that only backwashes injector plugs are located in both holes.

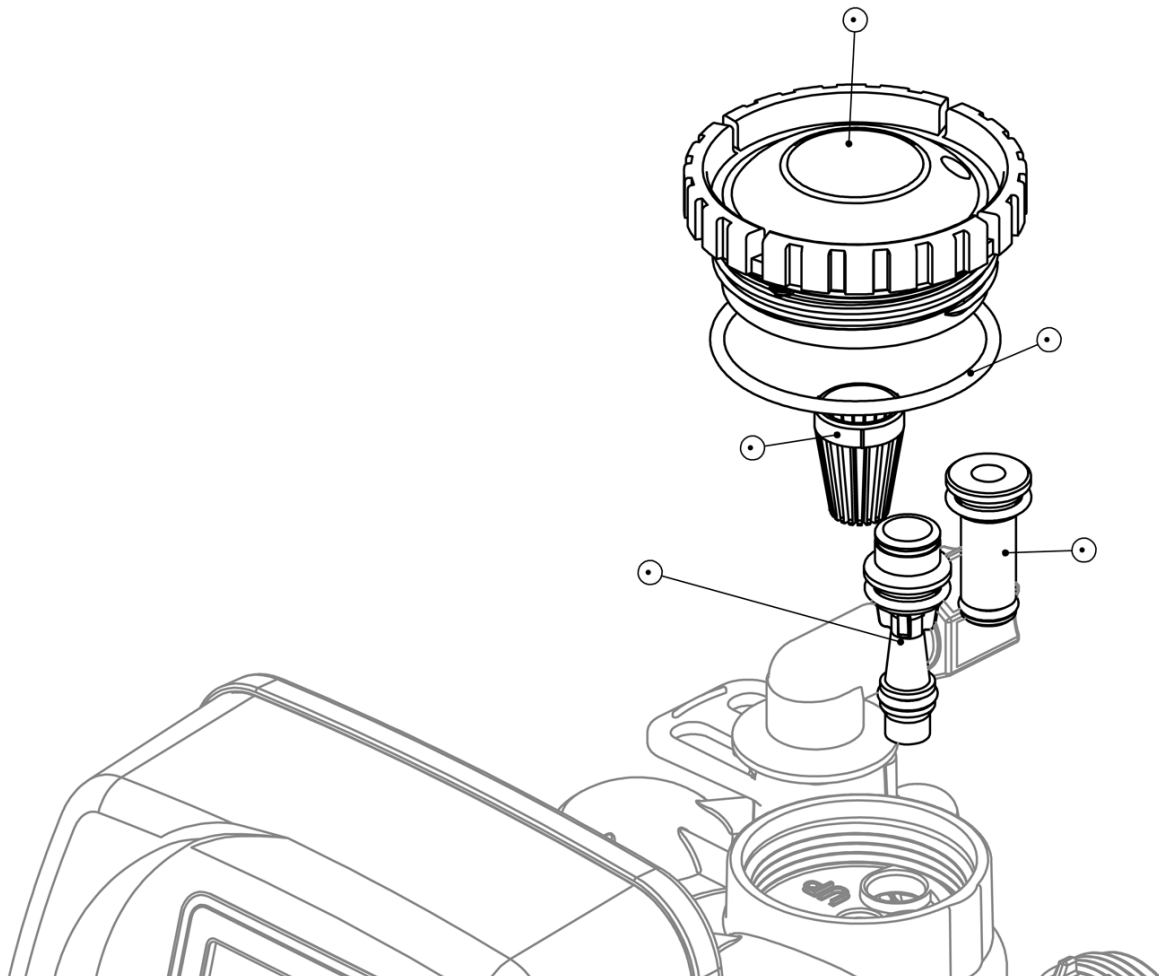

Brine Elbow Assembly Breakdown

Drawing No.	Order No.	Description	Quantity
1	V3195-01	WS1 Refill Port Plug ASY	This part is required for backwash only systems
2	H4615	Elbow Locking Clip	1
3	JCP-P-6	Polytube insert 3/8	1
4	JCPG-6PBLK	Nut 3/8	1
5	H4613	Elbow Cap 3/8	1
6	V3163	O-ring 019	1
7	V3165-01*	WS1 RFC Retainer ASY	1
8	V3182	WS1 RFC	1
Not Shown	H4650	Elbow 1/2" with nut and insert	Option

*Assembly includes WS1 RFC.

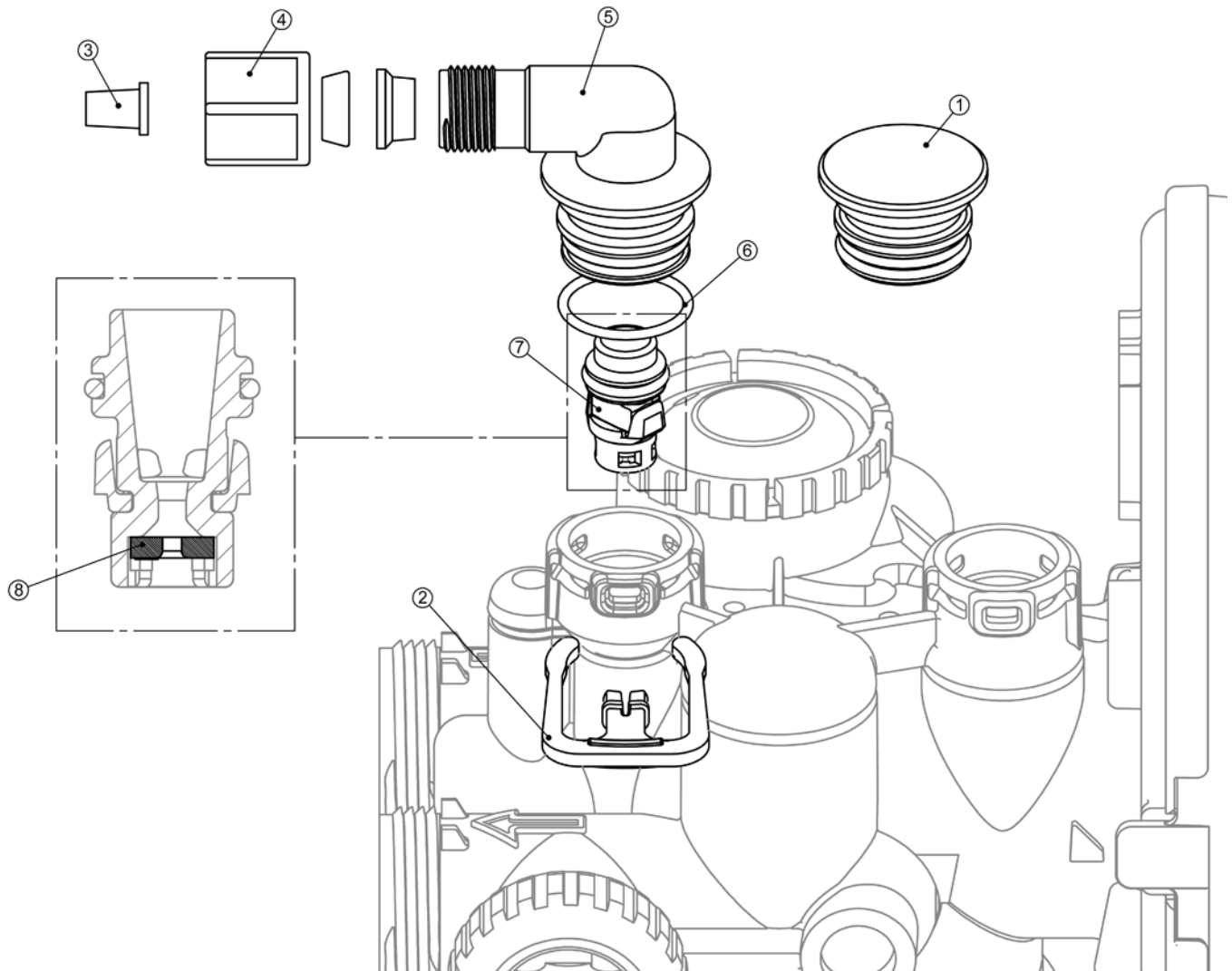

3/4" Drain Fitting Breakdown

Drawing No.	Order No.	Description	Quantity
1	H4615	Elbow Locking Clip	1
2	PKP10TS8-BULK	Polytube insert 5/8	Option
3	V3192	WS1 Nut 3/4 Drain Elbow	Option
4	V3158-01	WS1 Drain Elbow 3/4 Male ASY	1
5	V3163	O-ring 019	1
6	V3159-01	WS1 DLFC Retainer ASY	1
7	V3162-007	WS1 DLFC 0.7 gpm for 3/4	One DLFC must be used if 3/4 fitting is used
	V3162-010	WS1 DLFC 1.0 gpm for 3/4	
	V3162-013	WS1 DLFC 1.3 gpm for 3/4	
	V3162-017	WS1 DLFC 1.7 gpm for 3/4	
	V3162-022	WS1 DLFC 2.2 gpm for 3/4	
	V3162-027	WS1 DLFC 2.7 gpm for 3/4	
	V3162-032	WS1 DLFC 3.2 f gpm or 3/4	
	V3162-042	WS1 DLFC 4.2 gpm for 3/4	
	V3162-053	WS1 DLFC 5.3 gpm for 3/4	

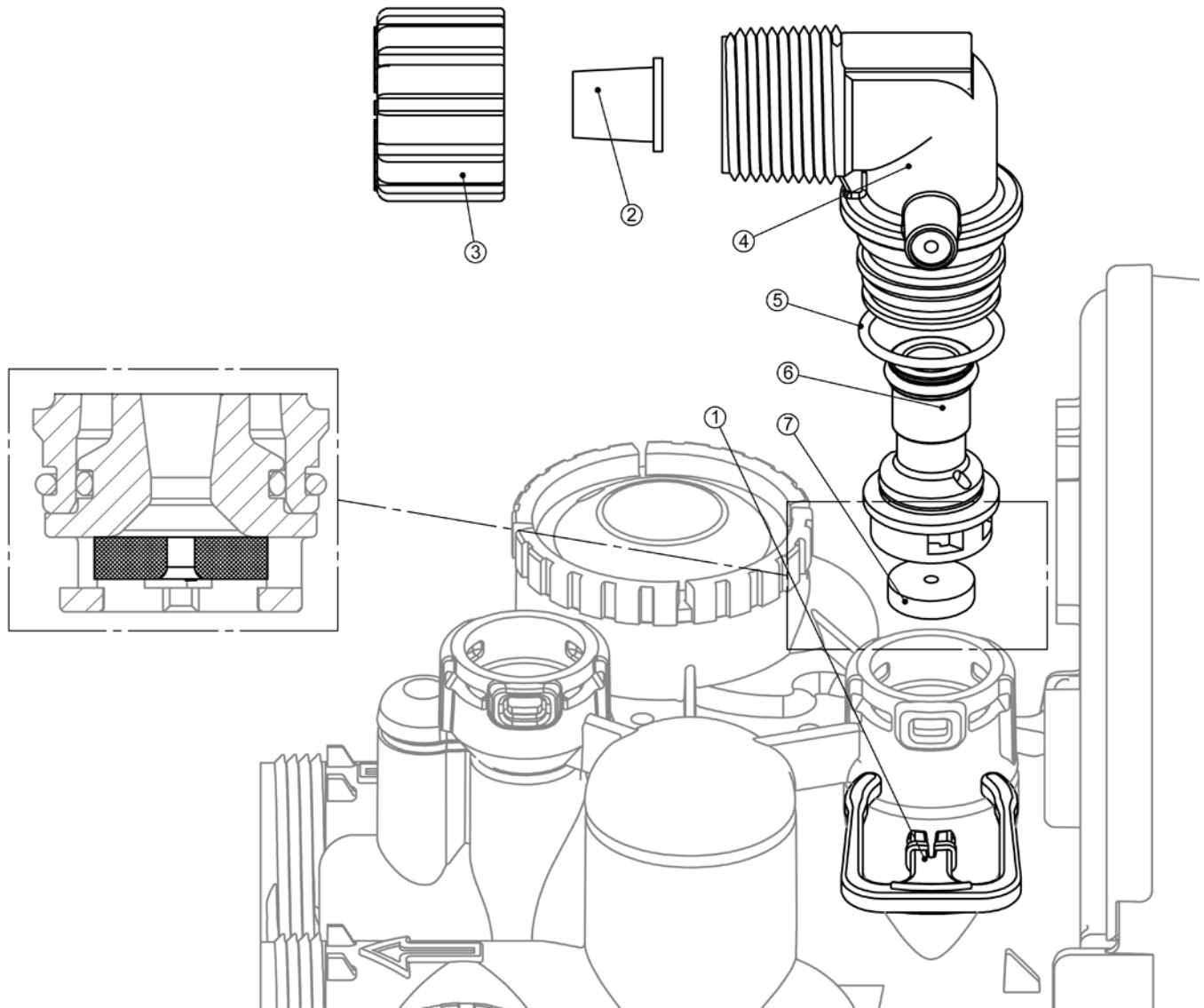

1" Drain Fitting Breakdown

Drawing No.	Order No.	Description	Quantity
1	H4615	Elbow Locking Clip	1
2	V3008-02	WS1 Drain FTG 1 Straight	1
3*	V3166	WS1 Drain FTG Body 1	1
4*	V3167	WS1 Drain FTG Adapter 1	1
5*	V3163	O-ring 019	1
6*	V3150	WS1 Split Ring	1
7*	V3151	WS1 Nut 1" QC	1
8*	V3105	O-ring 215	1
9	V3190-065	WS1 DLFC 6.5 gpm for 1	One DLFC must be used if 1 fitting is used
	V3190-075	WS1 DLFC 7.5 gpm for 1	
	V3190-090	WS1 DLFC 9.0 gpm for 1	
	V3190-110	WS1 DLFC 11.0 gpm for 1	
	V3190-130	WS1 DLFC 13.0 gpm for 1	
	V3190-170	WS1 DLFC 17.0 gpm for 1	
	V3190-200	WS1 DLFC 20.0 gpm for 1	
	V3190-250	WS1 DLFC 25.0 gpm for 1	

* Can be ordered as a set order number V3008-02, description: WS1 Drain FTG 1 Straight.

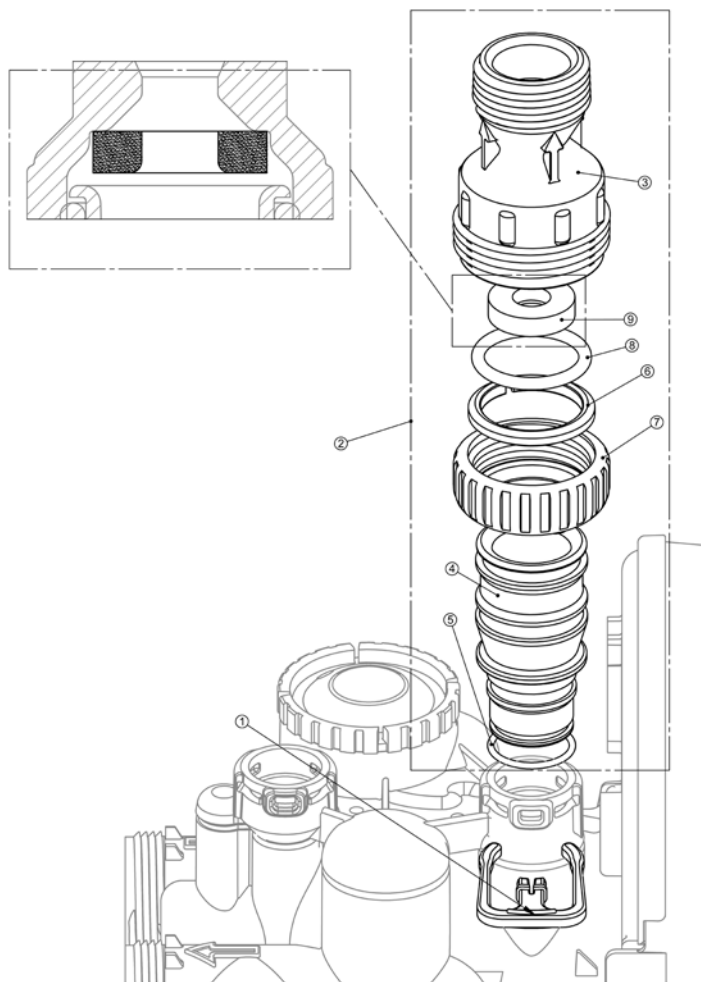

Meter Assembly Breakdown

Drawing No.	Order No.	Description	Quantity
1	V3151	WS1 Nut 1" QC	1
2	V3003*	WS1 Meter ASY	1
3	V3118-01	WS1 Turbine ASY	1
4	V3105	O-ring 215	1
5	V3003-01	WS1 Meter Plug ASY	1

*Order number V3003 includes V3118-01 and V3105.

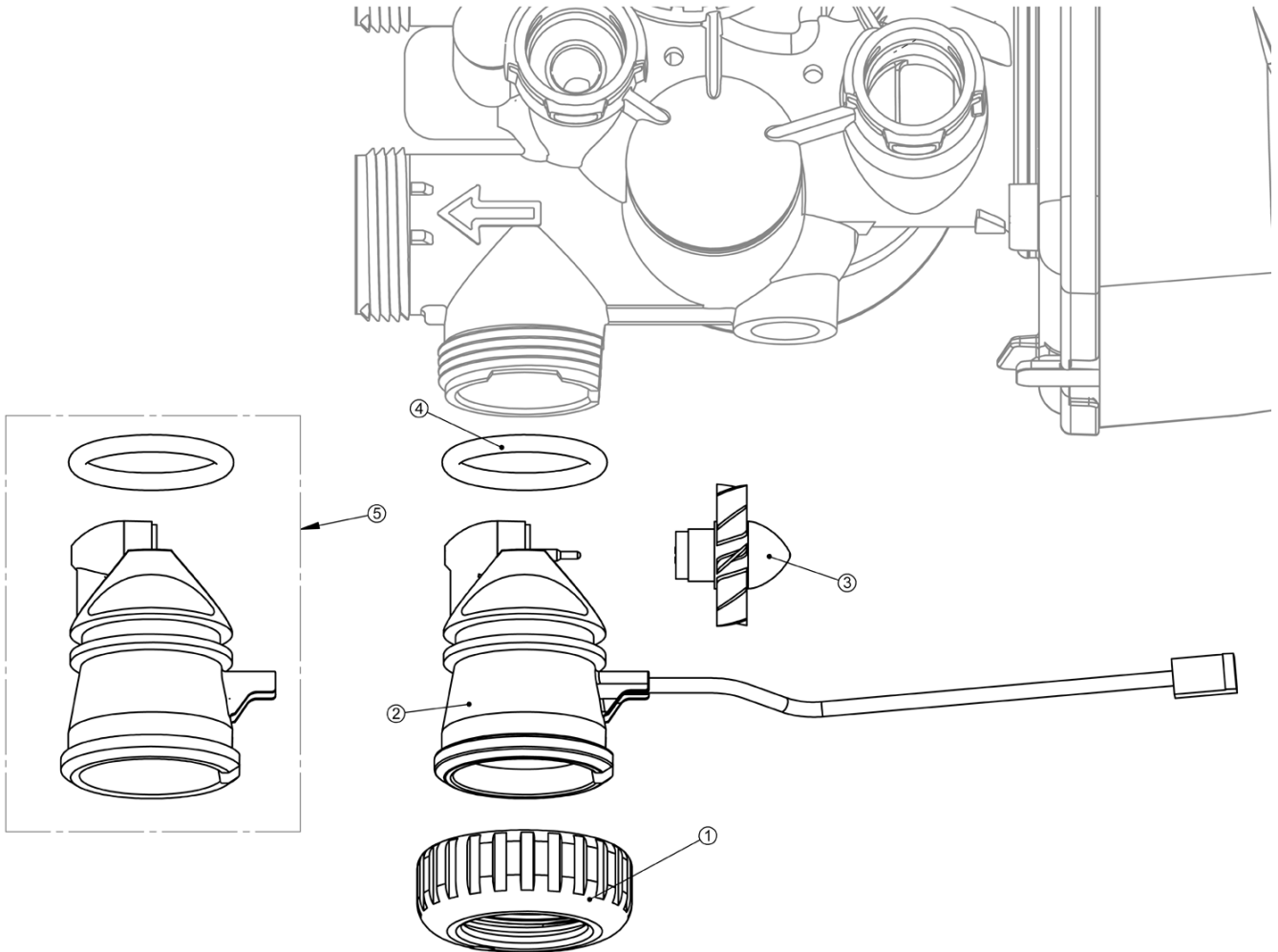

Order No: **V3007**

Description: **WS1 Fitting 1" PVC Male NPT Elbow Assembly**

Drawing No	Order No.	Description	Quantity
1	V3151	WS1 Nut 1" Quick Connect	2
2	V3150	WS1 Split Ring	2
3	V3105	O-Ring 215	2
4	V3149	WS1 Fitting 1 PVC Male NPT Elbow	2

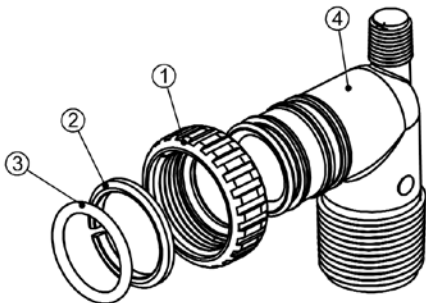

Order No: **V3007-01**

Description: **WS1 Fitting 3/4" & 1" PVC Solvent 90° ASY**

Drawing No.	Order No.	Description	Quantity
1	V3151	WS1 Nut 1" Quick Connect	2
2	V3150	WS1 Split Ring	2
3	V3105	O-Ring 215	2
4	V3189	WS1 Fitting 3/4" & 1" PVC Solvent 90	2

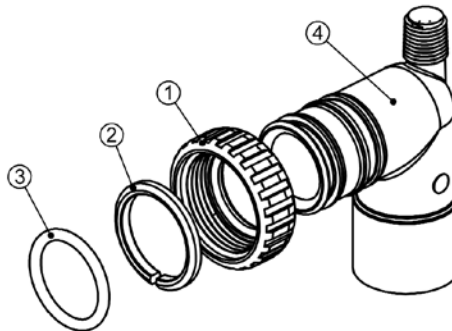

Order No: **V3007-02**

Description: **WS1 Fitting 1" Brass Sweat Assembly**

Drawing No.	Order No.	Description	Quantity
1	V3151	WS1 Nut 1" Quick Connect	2
2	V3150	WS1 Split Ring	2
3	V3105	O-Ring 215	2
4	V3188	WS1 Fitting 1 Brass Sweat	2

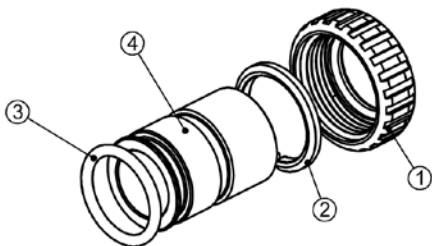

Order No: **V3007-03**

Description: **WS1 Fitting 3/4" Brass Sweat Assembly**

Drawing No.	Order No.	Description	Quantity
1	V3151	WS1 Nut 1" Quick Connect	2
2	V3150	WS1 Split Ring	2
3	V3105	O-Ring 215	2
4	V3188-01	WS1 Fitting 3/4" Brass Sweat	2

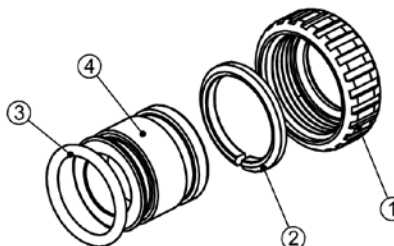

Bypass Assembly Breakdown

Drawing No.	Order No.	Description	Quantity
1	V3151	WS1 Nut 1" Quick Connect	2
2	V3150	WS1 Split Ring	2
3	V3105	O-Ring 215	2
4	V3145	WS1 Bypass 1" Rotor	2
5	V3146	WS1 Bypass Cap	2
6	V3147	WS1 Bypass Handle	2
7	V3148	WS1 Bypass Rotor Seal Retainer	2
8	V3152	O-ring 135	2
9	V3155	O-ring 112	2
10	V3156	O-ring 214	2

(Not Shown) Order No. V3191-01, Description: WS1 Bypass Vertical Adapter Assembly

Order No.	Description	Quantity
V3151	WS1 Nut 1" Quick Connect	2
V3150	WS1 Split Ring	2
V3105	O-Ring 215	2
V3191-01	WS1 Bypass Vertical Adapter Assembly	2

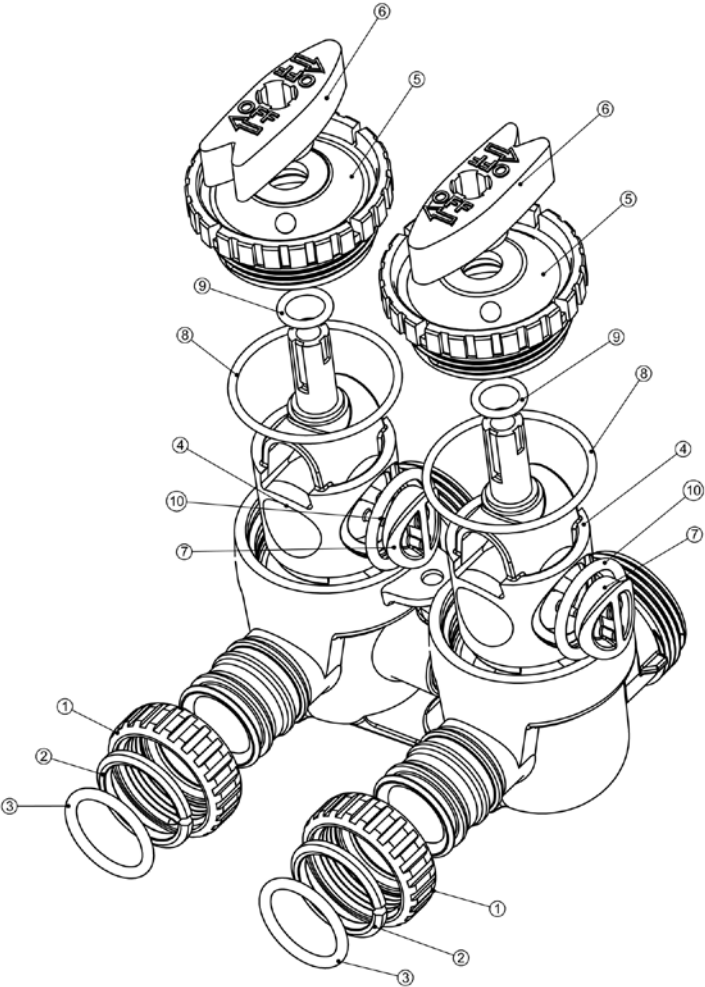

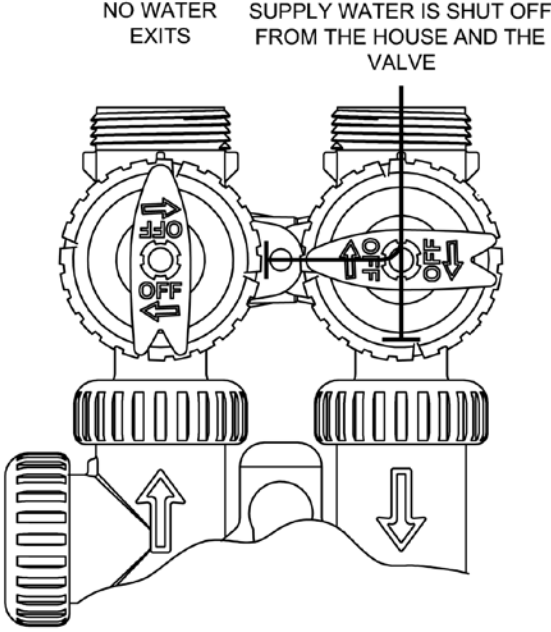
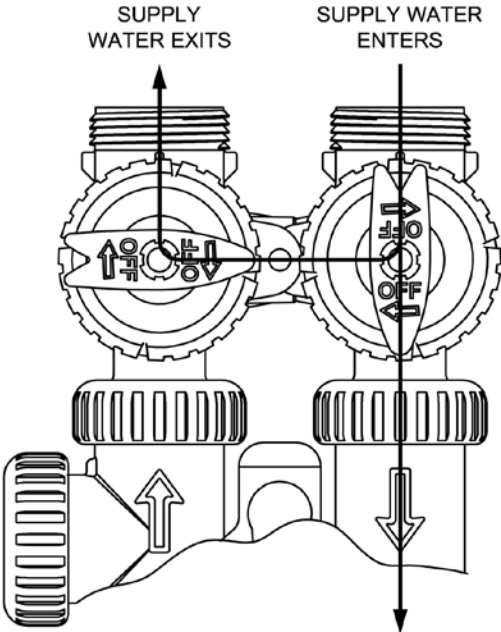
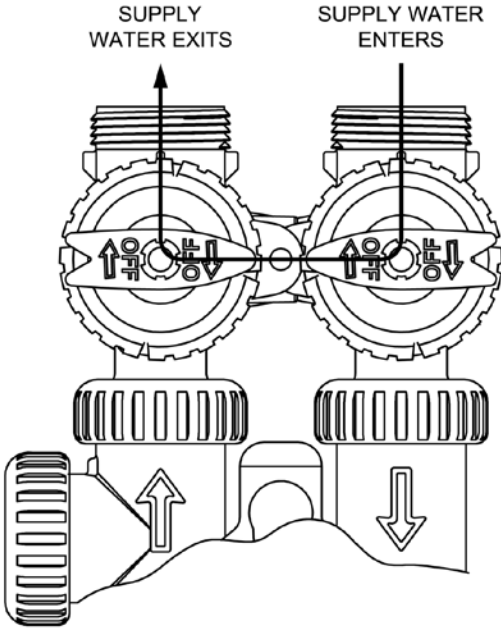
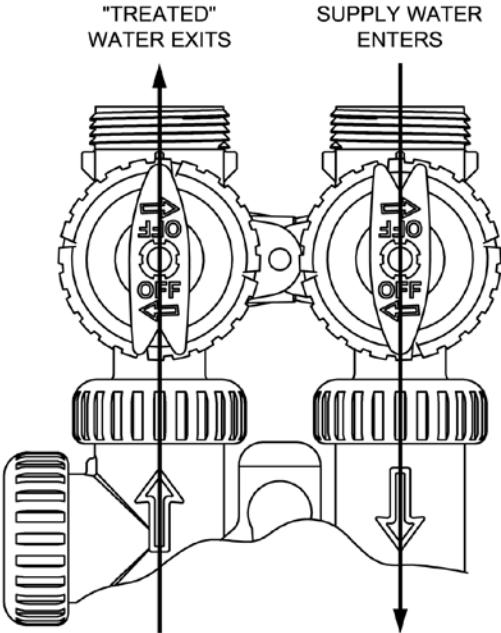

Trouble Shooting Procedures

Troubleshooting Procedures

Problem	Possible Cause	Solution
1. Timer does not display time of day	a. Transformer unplugged	a. Connect power
	b. No electric power at outlet	b. Repair outlet or use working outlet
	c. Defective transformer	c. Replace transformer
	d. Defective PC board	d. Replace PC board
2. Timer does not display correct time of day	a. Switched outlet	a. Use uninterrupted outlet
	b. Power outage	b. Reset time of day
	c. Defective PC board	c. Replace PC board
3. No softening/filtering display when water is flowing	a. Bypass valve in bypass position	a. Put bypass valve in service position
	b. Meter connection disconnected	b. Connect meter to PC board
	c. Restricted/stalled meter turbine	c. Remove meter and check for rotation or foreign material
	d. Defective meter	d. Replace meter
	e. Defective PC board	e. Replace PC board
4. Control valve regenerates at wrong time of day	a. Power outages	a. Reset control valve to correct time of day
	b. Time of day not set correctly	b. Reset to correct time of day
	c. Time of regeneration incorrect	c. Reset regeneration time
	d. Control valve set at "on 0" (immediate regeneration)	d. Check control valve set-up procedure regeneration time option
	e. Control valve set at NORMAL + on 0	e. Check control valve set-up procedure regeneration time option
5. ERROR followed by code number Error Code 1001 -Unable to recognize start of regeneration Error Code 1002 – Unexpected stall Error Code 1003 – Motor ran to long, timed out trying to reach next cycle position Error Code 1004 - Motor ran to long, timed out trying to reach home position If other Error Codes display contact the factory.	a. Control valve has just been serviced	a. Press NEXT and REGEN for 3 seconds or unplug power source jack (black wire) and plug back in to reset control valve
	b. Foreign matter is lodged in control valve	b. Check piston and spacer stack assembly for foreign matter
	c. High drive forces on piston	c. Replace piston(s) and spacer stack assembly
	d. Control valve piston not in home position	d. Press NEXT and REGEN for 3 seconds or unplug power source jack (black wire) and plug back in to reset control valve
	e. Motor not inserted fully to engage pinion, motor wires broken or disconnected, motor failure	e. Check motor and wiring. Replace motor if necessary
	f. Drive gear label dirty or damaged, missing or broken gear	f. Replace or clean drive gear
	g. Drive bracket incorrectly aligned to back plate	g. Reseat drive bracket properly
	h. PC board is damaged or defective	h. Replace PC board
	i. PC board incorrectly aligned to drive bracket	i. Ensure PC board is correctly snapped on to drive bracket

Problem	Possible Cause	Solution
6. Control valve stalled in regeneration	a. Motor not operating	a. Replace motor
	b. No electric power at outlet	b. Repair outlet or use working outlet
	c. Defective transformer	c. Replace transformer
	d. Defective PC board	d. Replace PC board
	e. Broken drive gear or drive cap assembly	e. Replace drive gear or drive cap assembly
	f. Broken piston retainer	f. Replace drive cap assembly
	g. Broken main or regenerant piston	g. Replace main or regenerant piston
7. Control valve does not regenerate automatically when REGEN button is depressed and held	a. Transformer unplugged	a. Connect transformer
	b. No electric power at outlet	b. Repair outlet or use working outlet
	c. Broken drive gear or drive cap assembly	c. Replace drive gear or drive cap assembly
	d. Defective PC board	d. Replace PC board
8. Control valve does not regenerate automatically but does when REGEN button is depressed	a. By-pass valve in bypass position	a. Put control valve in service position
	b. Meter connection disconnected	b. Connect meter to PC board
	c. Restricted/stalled meter turbine	c. Remove meter and check for rotation or foreign matter
	d. Defective meter	d. Replace meter
	e. Defective PC board	e. Replace PC board
	f. Set-up error	f. Check control valve set-up procedure
9. Time of day flashes on and off	a. Power has been out more than two hours, the transformer was unplugged and then plugged back into the wall outlet, the transformer plug was unplugged and then plugged back into the board or the NEXT and REGEN buttons were pressed to reset the valve.	a. Reset the time of day

