



---

## Series 972SM

---

**Single Metered Water Softening System 1.25”**



**Operation and Maintenance Manual**



## Table of Contents

<b>System Specifications and Warnings .....</b>	<b>4</b>
<b>Introduction .....</b>	<b>5</b>
<b>Installation Instructions .....</b>	<b>9</b>
<b>Start-Up Instructions .....</b>	<b>13</b>
<b>Series 972 Control Valve Programming .....</b>	<b>14</b>
<b>Manually Regenerating the Water Softener .....</b>	<b>18</b>
<b>Parts Breakdown</b>	
<b>Front Cover and Drive Assembly .....</b>	<b>21</b>
<b>Main Body Internal Parts .....</b>	<b>22</b>
<b>Injector Housing Assembly .....</b>	<b>23</b>
<b>Meter Assembly .....</b>	<b>24</b>
<b>Brine Elbow Refill Flow Assembly and Refill Port Plug .....</b>	<b>25</b>
<b>Drain Line Assembly .....</b>	<b>26</b>
<b>1" Drain Assembly .....</b>	<b>27</b>
<b>Bypass Assembly Breakdown .....</b>	<b>28</b>
<b>Bypass Valve Operation .....</b>	<b>29</b>
<b>Installation Fitting Assemblies .....</b>	<b>30</b>
<b>Brine Tank Assembly .....</b>	<b>32</b>
<b>System Specifications .....</b>	<b>33</b>
<b>Service Instructions .....</b>	<b>35</b>
<b>Water Softener Log Sheet .....</b>	<b>40</b>
<b>Troubleshooting the Control Valve .....</b>	<b>41</b>
<b>Manufacturer's Warranty .....</b>	<b>47</b>

## System Specifications and Warnings

### System Specifications

Water pressure: 40 psi minimum 100 psi Maximum

Water Temperature: 40°F to 110°F

Electrical Requirements:

Supply Voltage: 120V

Supply Frequency: 60Hz

Output Voltage: 12V AC

Output Current: Maximum 3.0 Amps

Water Meter:

Pipe Size: 3/4"-1.25"

Accuracy: ± 5%

Minimum Flow : 0.25 GPM

Control Valve to Tank Connection: 2.5"-8UN

Control Valve Distributor Pipe Connection: 1.32"

Circuit Board Memory: NonVolatile EEPROM (**E**lectrical **E**rasable **P**rogrammable **R**ead **O**nly **M**emory)

Compatible with the following typical concentrations of regenerant chemicals: Sodium Chloride, Potassium Chloride, Potassium Permanganate, Sodium Bisulfite, Chlorine and Chloramines



### Warnings

The control valve and fittings are not designed to support the weight of the system or the plumbing.

Do not use Vaseline, oils, other hydrocarbon lubricants or spray silicone anywhere. A silicone lubricant may be used on black O-rings.

Hydrocarbons such as kerosene, benzene, gasoline, etc., may damage products that contain O-rings or plastic components. Exposure to such hydrocarbons may cause the products to leak. Do not use the product(s) contained in this document on water supplies that contain hydrocarbons such as kerosene, benzene, gasoline, etc.

The water meter should not be used as the primary monitoring device for critical or health effect applications.

Do not use pipe dope or other sealants on threads. Teflon tape is recommended to be used on all threads. Use of pipe dope may break down the plastics in the control valve.

## 1. INTRODUCTION

Long term, successful operation of any water softening system depends upon the care and attention it receives. Ordinarily, water treatment systems will provide uniform performance after the initial start-up period and operation is stable. Gallonage delivery between regenerations and treated water purity usually do not vary appreciably over the life of the resins--as long as the mineral content of the incoming water does not change.

This manual is intended to be a practical reference guide for all operating personnel. In view of the fact that system performance can change very dramatically throughout the year, a discussion of "ion exchange" theory is included in addition to basic information relative to equipment operation and regeneration procedures. Thorough understanding of the simple chemical reactions will help to determine if some equipment malfunction has occurred, or if the system is simply responding to changing water conditions. For this reason, all operation and supervising personnel are encouraged to study Section 2, which define terminology and the simple chemistry associated with this system.

Ion exchange (i.e., the softening process) is a reversible reaction. Ion exchange softening resins have only a limited capacity for removing calcium and magnesium minerals. If the volume of water put through a resin bed exceeds its capacity, some hardness will start sloughing off into the treated water. Therefore, service runs must be terminated before this breakthrough occurs. When a run is over, the resins are treated with sodium chloride salt to displace the hardness and restore its removal capacity again. This process is termed "regeneration".

The degree of softening that can be accomplished depends upon several factors. The primary influences are the incoming water composition, type of resins used and amount of salt used. Secondary influences are the concentrations and flow-rates at which NaCl is applied.

## 2. PRINCIPLES OF ION EXCHANGE IN THE SOFTENING PROCESS

### 2.1 ION EXCHANGE SOFTENING PROCESS

In order to understand what happens in the ion exchange softening process, it will first be necessary to understand the meaning of the terms that are used in the explanation. HARD WATER, CATION EXCHANGER, and BRINE are therefore defined below and then used to show how the ion exchange process works.

A. *Hard Water* - All natural waters contain much the same dissolved impurities, but in widely varying amounts. There are always enough ANIONS (-) present to balance the CATIONS (+), but anions have no effect on the ion exchange softening process. Water will be HARD, if it contains large amounts of Calcium (Ca++) and/or Magnesium (Mg++) ions.

B. *Brine* - water in which SALT has dissolved. SATURATED brine contains as much salt as it is possible to hold in solution (approx. 26% to 27%).

SALT - SODIUM CHLORIDE (NaCl). When dissolved in water it splits up (ionizes) into Sodium (Na+) ions and Chloride (Cl-).

SATURATED BRINE - contains a very great number of Na+ and Cl- ions (concentration is over 200,000 ppm). When used to regenerate a CATION EXCHANGER, only the Sodium ions (Na+) are put to use. The Chloride ions (Cl-) do not work in the process.

C. *Cation Exchanger* - a solid material that has a very large number of "REACTION POINTS". These reaction points have NEGATIVE (-) electric charges, and are able to attract and hold CATIONS, which are POSITIVELY (+) charged (much the same way as the way opposite poles of a magnet attract each other).

## Introduction

- D. *The Softening Process* - When  $\text{Ca}^{++}$  or  $\text{Mg}^{++}$  ions have occupied most of the reaction points, hardness will begin to slip through the bed in increasing amounts. This rise in hardness in the effluent is an indication that the effective capacity of the CATION EXCHANGER has been reached. The CATION EXCHANGER must then be regenerated to restore it to its original condition.
- E. *Regeneration* - A solution of NaCl is applied to the CATION EXCHANGER at a controlled rate and the softening process is reversed. The  $\text{Ca}^{++}$  and  $\text{Mg}^{++}$  ions are driven off of the CATION EXCHANGER and replaced with  $\text{Na}^{+}$  ions. At the end of regeneration, the "spent" brine is rinsed away and the REGENERATED CATION EXCHANGER, with its reaction points again occupied by sodium ions - is again able to soften HARD WATER.

### 2.2 QUALITY OF EFFLUENT

If the hard water contains less than 500 ppm (about 30 grains) of Calcium, Magnesium and Sodium salts, all expressed as  $\text{CaCO}_3$ , it will be found that the effluent from a softener will contain an average of not more than 2 ppm actual total hardness (Zero hardness by the SOAP TEST). However, as the total CATION concentration in the hard water increases above 500 ppm, the average hardness in the effluent will also increase proportionately.

The reason for this is that when the sodium salt - those present in the raw water plus those formed by the exchange reactions - are present in high enough concentrations, they cause a "back-regeneration" effect at the same time as the softening process is taking place. This effect prevents as complete a removal of calcium and magnesium as would otherwise be possible.

It is often possible to reduce the average hardness in the effluent below normally expected concentrations, by using a greater amount of salt than usual for regeneration.

Normal Softening Cycle - At the start of a normal softening cycle, the hardness in the effluent drops rapidly as the residue of hardness ions left in the bed at the end of the rinse are forced out. The effluent hardness reaches a certain minimum value and remains at approximately this concentration for the major part of the softening run.

### 2.3 CAPACITY OF ION EXCHANGER

The capacity for the removal of calcium and magnesium depends mainly upon the type of ion exchanger that is used. It is further influenced by the amounts of hardness and sodium ions in the raw water, and by the amount of salt used for regeneration.

- A. *Raw Water* - The effect of the amounts of hardness and sodium ions in the raw water, is expressed in terms of COMPENSATED HARDNESS. The hardness of the raw water is considered to be greater than it actually is for capacity determinations, whenever: (a) the total hardness is greater than 400 ppm (as  $\text{CaCO}_3$ ), or (b) the sodium salts are over 100 ppm as ( $\text{CaCO}_3$ ). This "greater-than-actual" hardness is referred to as COMPENSATED HARDNESS.
- B. *Salt Dosage* - The capacity that will be obtained from a cation exchanger is also determined by the amount of salt used during regeneration. The Kilograins (kgr) of hardness that can be removed by each cubic foot of ion exchanger between regenerations increases as more salt is used for regeneration.

At the same time, the efficiency of salt usage decreases with the higher regenerant dosages. That is, a greater number of Kilograins of hardness are removed for each pound of salt used at the lower salt dosages, (and consequently, at the lower capacities). Thus, greater economy may be obtained at the expense of the number of gallons of water softened between regenerations.

### 3. NORMAL OPERATOR RESPONSIBILITIES

Long term, reliable system performance depends upon how conscientiously the equipment is operated and maintained. Operator responsibilities to assure operation should include the following recommended practices:

#### 3.1 MAINTAIN OPERATING LOGS

Operators should maintain close control of the process by monitoring system performance daily. Effluent purity, hardness leakage, service run lengths and pressure drop across the bed must be recorded faithfully. Since resins are subject to fouling, decrease in product quality or run length could be the result of fouling. In addition to operating data, log notations should include chemical delivery dates, equipment design changes, or modifications in program settings. This information can be invaluable if troubleshooting is ever required.

The daily log should be updated once or twice a shift and should include the following information:

1. Dates and Time
2. Which softener is on-line
3. Inlet and Outlet pressure gauge readings; calculated pressure drop
4. Influent hardness
5. Effluent hardness
6. Gallon capacity remaining
7. Record salt usage
8. Any equipment design changes, or modifications in programmed cycle settings or capacity settings

### 4. OPERATING & REGENERATION PROCEDURES

#### 4.1 DESCRIPTION OF OPERATION

The system is designed for fully automatic operation. Unit meters water and regenerates based upon water used.

#### 4.2 REGENERATION CYCLE

##### A. SERVICE

During service flow, raw water passes through the inlet of the control valve and down-flow through the resin bed, through the lower hub and lateral distribution system, up the distributor pipe and exits through the outlet of the control valve and into the service lines. Service flow continues until the preset gallonage has been used, initiating the regeneration process.

##### B. BACKWASH

Raw water passes through the inlet of the control valve and is directed down through the distributor pipe to the bottom of the tank. Water flow passes through the lower hub and lateral distribution system and travels up-flow through the resin bed. The water expands the bed scrubbing the resin beads and washing any entrapped dirt out through the control valve drain port and out to drain. Backwash sequence lasts approximately 10 minutes.

##### C. BRINE AND SLOW RINSE

Raw water is directed through the injector built into the main regeneration control. A venturi action in the injector draws the required amount of brine into the softener. The solution of salt water then passes down-flow through the resin bed, through the lower

## Introduction

hub and lateral distribution system, up the distributor pipe and exits through the drain port of the control valve and out to drain. The level of water in the brine tank should be drawn down from the preset level. The brine float air-check valve shuts off air when the preset drawdown is reached. Raw water continues to the drain through the main control valve slow rinsing the resin for the remainder of the cycle. Brine and slow rinse sequence lasts approximately 60 minutes.

D. **SECOND BACKWASH**

Water flow is the same as the first backwash. This step in the regeneration process helps to remove iron that was released from the resin during the Brine cycle. The second Backwash sequence lasts approximately 6 minutes.

E. **FAST RINSE**

Raw water passes through the inlet of the control valve and down-flow through the resin bed, through the lower hub and lateral distribution system, up the distributor pipe and exits through the drain port of the control valve and out to drain. This sequence removes all remaining brine from the resin bed. The Fast Rinse sequence lasts approximately 10 min.

F. **BRINE REFILL**

When the regeneration cycle is finished, fresh water flows through the brine line and into the brine tank refilling it to the preset level. The brine valve float will control water makeup level.

**A WORD OF CAUTION -- DON'T ARBITRARILY MAKE CHANGES, IF YOU WISH TO MAINTAIN EFFICIENT REGENERATIONS.**



## Installation Instructions

### Pre-Installation Checklist

1. A standard electrical outlet (120V/160Hz) must be located within 12' of installation site.
2. A functioning floor drain, washer stand pipe or suitable location for waste water discharge must be located within 20' of installation site.
  - a. All plumbing should be done in accordance with local plumbing codes. The pipe size for the drain line should be a minimum of 1/2". Backwash flow rates in excess of 7 gpm or length in excess of 20' require 3/4" drain line.
3. A working pressure reducing valve must be installed on the inlet water line that supplies the water softener.
4. **(Note: The warranty is void if the system is exposed to water pressure in excess of 100 psi.)**
5. The temperature at the location of the water softener system must never be below 40°F.

### Installation

1. **Floor Space:** Make sure the floor space that has been selected to install the water softener is clean and on a level surface.
2. **Leveling the Salt Container:** If the floor beneath the salt container is not level, do not use shims or spacers to level the salt container. A platform that supports the entire bottom surface of the salt container must be used.
3. **What to Bypass:** A typical installation would include bypassing the outside hose bibs. The cold water feeding the kitchen sink may or may not be bypassed depending upon preference.
4. **Connection Kit:** The standard connection kit supplied with the water softener will be a 1.25" brass sweat connection kit. (See Figure 1) Other connection kits are available.

Figure 1

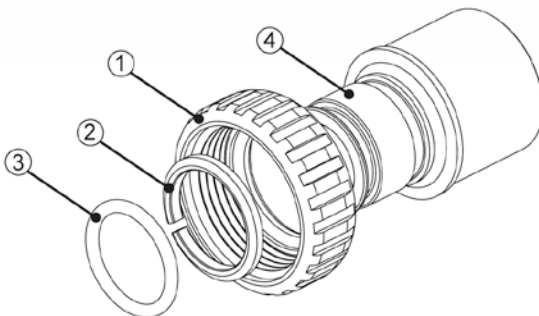

## Installation Instructions

**5. Plumbing Preparations:** Unscrew the two plastic nuts (#1) and pull on the two brass connectors (#4) to remove them from the bypass assembly. Next remove the white plastic rings (#2) and the O-rings. (#3) See *Figure 1*

- Solder at least 6" of pipe to the brass connectors before reassembly. (See *Figure 2*)
- After soldering is complete, cool the pipe and connectors. Slide the plastic nuts (#1) over the brass connectors (#4). Place the white plastic split rings (#2) into the grooves closest to the end of the brass connectors (#4). Reassembly the connection kit onto the bypass assembly.

**Warning:** When assembling the installation-fitting package (inlet and outlet), connect the fitting to the plumbing system first and then attach the nut, split ring and O-ring. Heat from soldering or solvent cements may damage the nut, split ring or o-ring. Solder joints should be cool and solvent cements should be set before installing the nut, split ring and O-ring. Avoid getting primer and solvent cement on any part of the O-rings, split rings, bypass valve or control valve.

**6. Plumbing:** When connecting the water softener to the existing plumbing, make sure the inlet water is connected to the inlet of the softener. Arrows on the valve body indicate direction of flow. Make sure the bypass valves are in the correct position See *Figure 3*.

**Note:** All plumbing should be done in accordance with local plumbing codes.

**Warning:** The control valve, fittings and/or bypass are designed to accommodate minor plumbing mis-alignments but are not designed to support the weight of a system or the plumbing.

**Figure 1**

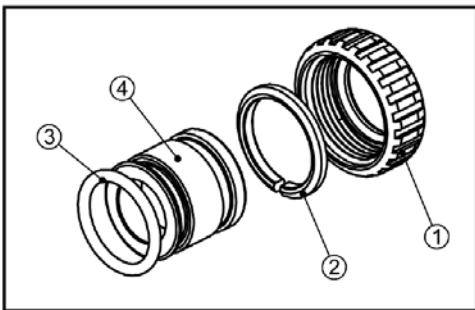

**Figure 2**

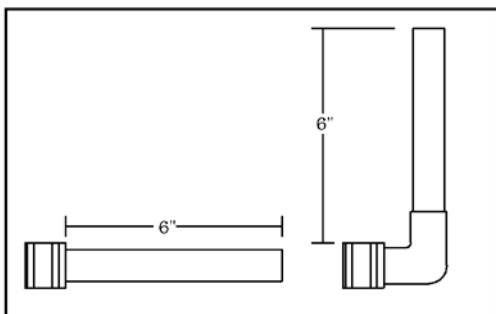

**Figure 3**

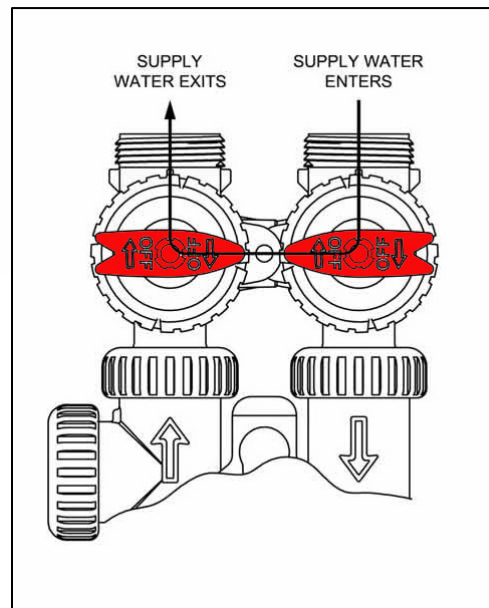

## Installation Instructions

7. **Locate Polytube Insert:** Now that the water softener is connected to the existing plumbing, the drain line may be connected. First, locate and remove the polytube insert (#2) from the gray cable on the left side of the control valve.

8. **Connecting the Drain Line:** Slide plastic nut (#3) over the permanent drain tubing and place the polytube insert (#2) into the end of the drain tubing. Insert the drain tubing into the drain elbow fitting (#4) and tighten plastic nut (#3) hand-tight plus 1/2 turn with pliers. **Caution:** Do Not Over-tighten. (See Figure 4)

**Figure 4**

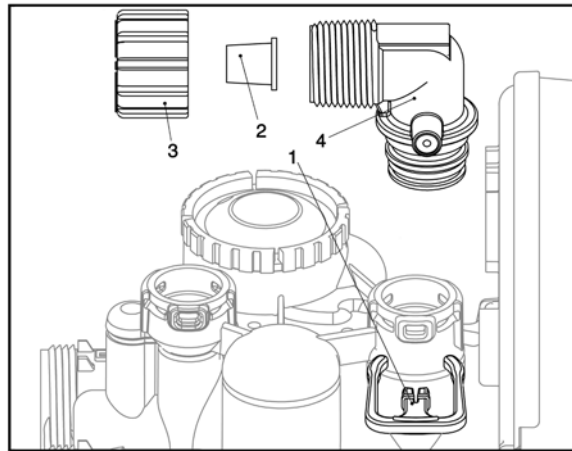

9. **Drain Line Specs:** If the distance from the water softener to the drain is greater than 20' the drain line size must be increased to 3/4". The threads on the drain elbow fitting are 3/4" male NPT and can be used in lieu of the 1/2" plastic nut and insert. If the drain line must run overhead, the maximum height of the drain line should not exceed 8' above the top of the water softener.

10. **Air Gap:** The drain line must have an approved air gap to prevent the possibility of a cross connection to the sewer. (See Figure 5)

**Figure 5**

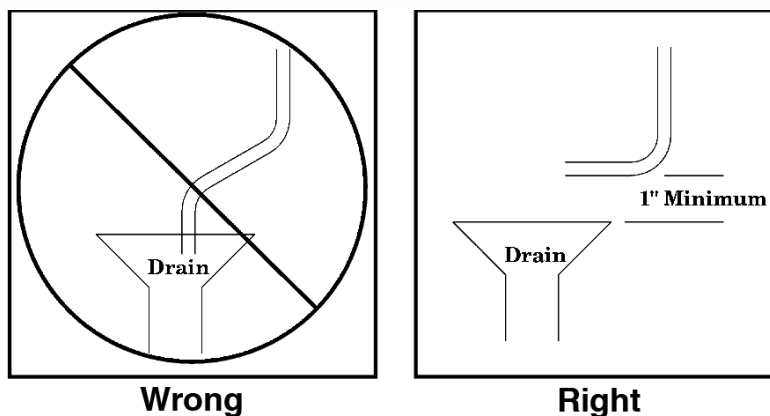

## Installation Instructions

11. **Connecting the overflow line:** The brine overflow fitting is located on the outside of the salt container approximately 12" down from the top. Connect 1/2" drain tubing to the overflow fitting and run it to the nearest floor drain. This line is a gravity flow line and cannot be run overhead or cannot connect to a drain that is higher than the overflow fitting.

12. **Connecting the brine line:** A 3/8" brine line approximately 4' long is attached to the salt container and is supplied with the tube insert (#2) in the end of the brine line. (See Figure 6) Unscrew the brine nut (#3) and slide it over the end of the brine line. Insert the brine line into the brine fitting. (#4) and tighten the brine nut (#3) hand tight plus 1/2 turn with pliers. **Caution:** Do Not Over-tighten.

**Figure 6**

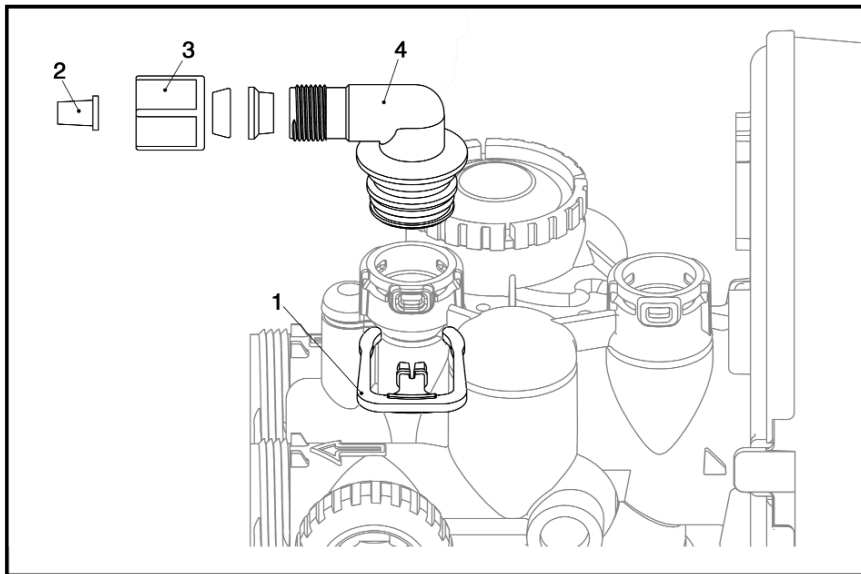

The water softener is equipped with a 15-foot power cord with built-in transformer. Plug the power cord into a standard (120V 60Hz) electrical outlet. It will take approximately 10 seconds before you will see the display (this is normal). The water softener is now ready to be programmed.

## Start-Up Instructions

### Start-Up

To begin, place the bypass in the position shown in Figure 1.

Place the softener in the Backwash cycle.

- To place the softener in the Backwash cycle press and hold the REGEN button (approx. 6 seconds) until the control valve initiates a regeneration cycle. The softener is now in the Backwash cycle. An initial burst of air will be released to the drain. Leave the unit in the Backwash cycle until the water running to the drain runs clear.
- Press the REGEN button to advance the controller to the next cycle. The softener is now in the Brine/Slow Rinse cycle.
- When the timer begins countdown press the REGEN button to advance the controller to the next cycle. The softener is now in the 2nd Backwash cycle.
- When the timer begins countdown press the REGEN button to advance the controller to the next cycle. The softener is now in the Fast Rinse cycle. Leave the unit in the Fast Rinse cycle for at least five minutes.
- While the system is rinsing manually fill the brine tank with fresh water until there is approximately 2" of water above the false bottom.
- Press the REGEN button to advance the controller to the next cycle. The softener is now in the Brine Tank Fill cycle. Leave the unit in the Brine Tank Fill cycle for at least one minute. This will ensure that there is no air trapped in the brine tubing and valve.



#### **IMPORTANT:**

**After the unit has filled for approximately 1 minute, raise the float to shut off the flow of water and then check the float valve, brine tubing and connections for leaks.**

- Press the REGEN button to advance the controller to the home position.
- Salt may be placed in the unit at this time.

To complete the Start-up place bypass in the position shown in Figure 2

Figure 1

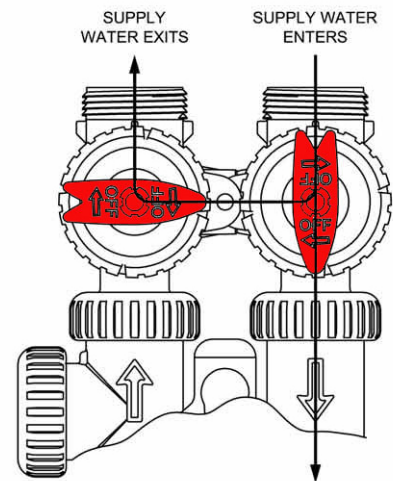
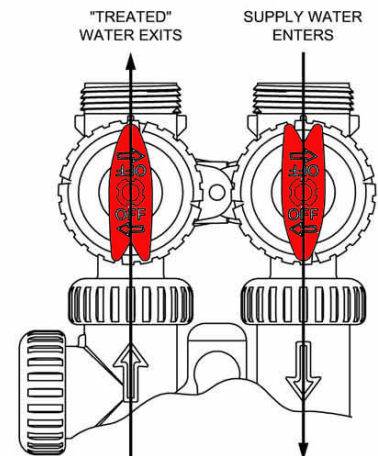

Figure 2



# Series 972 Control Valve Programming





# Control Valve Programming

## Programming

The control valve has been pre-programmed from the factory with the correct regeneration cycle program and cycle times. The gallon capacity between regeneration can be changed by adjusting the water hardness.

**Step 1** - Press the **NEXT** and the **UP** Arrow buttons at the same time and hold for 2 seconds.

**Step 2 - Raw Water Hardness:** Adjust to the correct hardness by pressing the **UP** or **DOWN** arrow button. Default setting 20 grains per gallon. Press **NEXT** to go to Step 3.

### Step 1

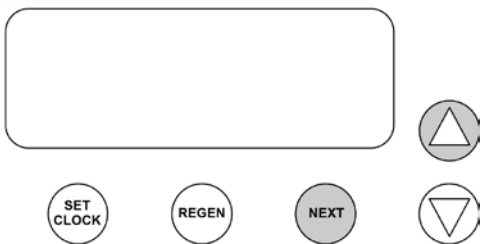

### Step 2



**Step 3 - Day Override:** This setting should be set to **15**. Press **NEXT** to go to Step 4.

**Step 4 - Regeneration Time:** The system regenerates at **2:00 AM**. This setting is adjustable. No water should be used during regeneration. (Typically this is the middle of the night.)

Press **NEXT** to exit programming.

### Step 3

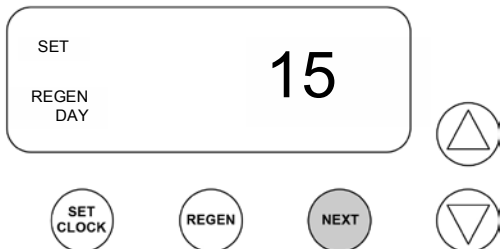

### Step 4

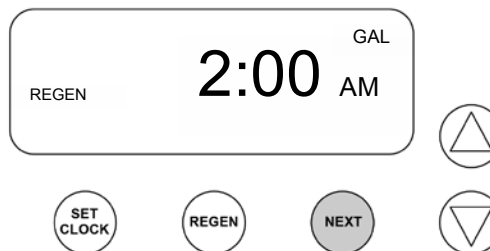

Exit Programming Mode



# Control Valve Programming

## Set the Time of Day

The time of day should only need to be set after initial installation or after an extended power outage. If an extended power outage has occurred, the time of day will flash indicating that it needs to be set.

**Step 1** - Press **SET CLOCK**

**Step 2** - **Current Time of Day - Hours:** Adjust to the correct hour by pressing the **UP** or **DOWN** arrow button. Press **NEXT** to go to Step 3.

**Step 3** - **Current Time of Day - Minutes:** Adjust to the correct minutes by pressing the up or down arrow button. Press **NEXT** to return to the normal operating screen.

### Step 2



### Step 3

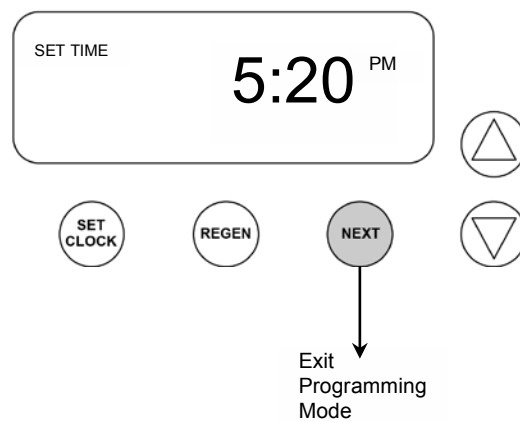

## Normal Operating Screens

During normal operation one of three screens can be displayed. Pressing the **NEXT** button alternates between these screens.

**Screen 1** - Current Time of Day

**Screen 2** - Capacity Remaining in Gallons

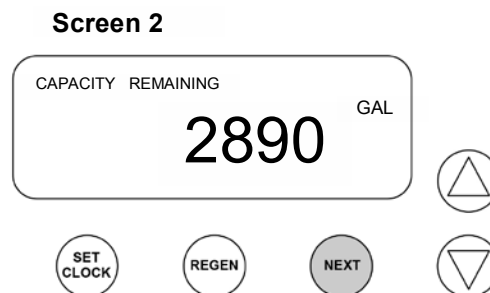

## Manually Regenerating the Water Softener

There are two different purposes and methods for manual regeneration of the water softener.

- **Delayed Regeneration**
- **Immediate Regeneration**

Reasons you may want to manually regenerate the water softener:

1. If the brine tank has run out of salt:
  - After adding salt to the brine tank manually regenerate the softener using the delayed regeneration method. *(The water needs time to dissolve the salt for a minimum of six hours.)*
  - To initiate a delayed regeneration simply push the REGEN button one time. *(Don't hold the button down)* REGEN TODAY will appear on the left hand side of the screen. The softener is queued to regenerate that day at the preset regeneration time. *(Typically this is in the middle of the night.)* If for some reason you want to cancel the delayed regeneration just push the REGEN button again. REGEN TODAY will no longer be visible on the screen.
2. If you have guests coming to stay in your home:
  - The water softener is programmed to measure the specific water usage of your family and regenerates based on water usage history. If you know that there will be extra people using the water you may want to manual regenerate the softener using the delayed regeneration method.
  - To initiate a delayed regeneration simply push the REGEN button one time. *(Don't hold the button down)* REGEN TODAY will appear on the left hand side of the screen. The softener is queued to regenerate that day at the preset regeneration time. *(Typically this is in the middle of the night.)* If for some reason you want to cancel the delayed regeneration just push the REGEN button again. REGEN TODAY will no longer be visible on the screen.
3. If the water is hard:
  - The quickest way to get soft water in your home is by initiating an immediate regeneration of the water softener.
  - To initiate an immediate regeneration of the water softener push and hold the REGEN button for approximately six seconds. The unit will immediately begin its regeneration cycle and water will be running to the drain. *(When the softener has completed the manual regeneration the system will automatically return to its preset normal operations.)*

**Note: After an immediate regeneration of the water softener there is typically a delay of three to four days to purge the system i.e. water heater, pipes etc. of the hard water. After the three to four day period is passed and there is still hard water present you may need to contact a service professional.**

# Parts Breakdown



## Parts Breakdown

### Front Cover and Drive Assembly

Drawing No.	Part No.	Description	Quantity
1	V3381-01ES	Front Cover Assembly	1
2	V3107-01	Drive Motor	1
3	V3106-01	Drive Bracket and Spring Clip	1
4	V3491ER	Circuit Board	1
5	V3110	Drive Reducing Gear	3
6	V3109	Drive Gear Cover	1
Not Shown	V3186	Transformer 110VAC-12VAC	1

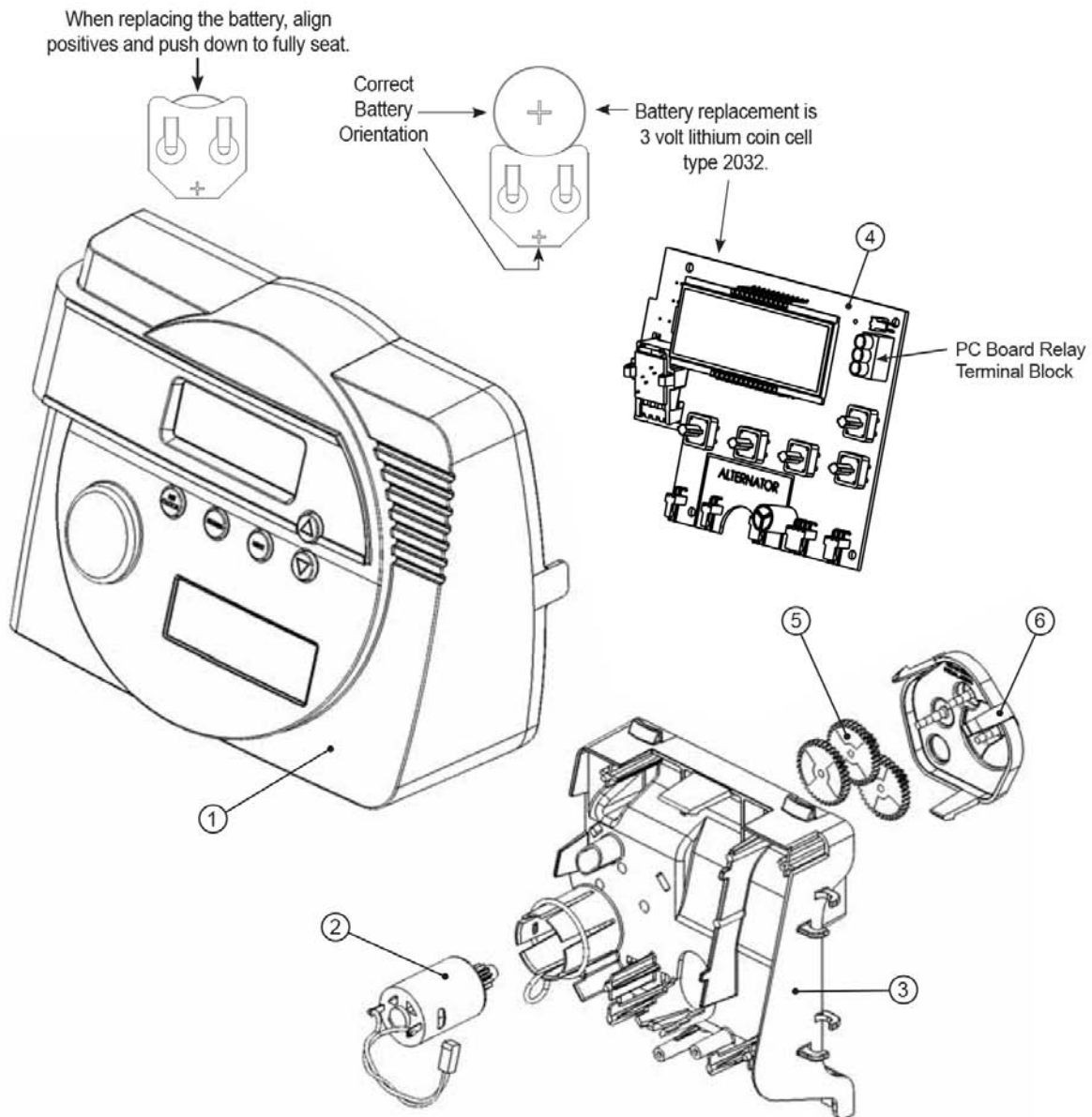

## Parts Breakdown

### Main Body Internal Parts

Drawing No.	Part No.	Description	Quantity
1	V3430	WS1.5 Spacer Stack Assembly	1
2	V3004	Drive Cap Assembly	1
3	V3382	Drive Back Plate	1
4	V3407	Piston Down-flow Assembly	1
5	V3174	Regenerant Piston	1
6	V3135	Drive Cap O-Ring	1
7	V3180	Tank O-Ring	1
8	V3105	Dist. Tube O-Ring 1.32"	1
8	V3357	Dist. Tube O-Ring 32 mm	1

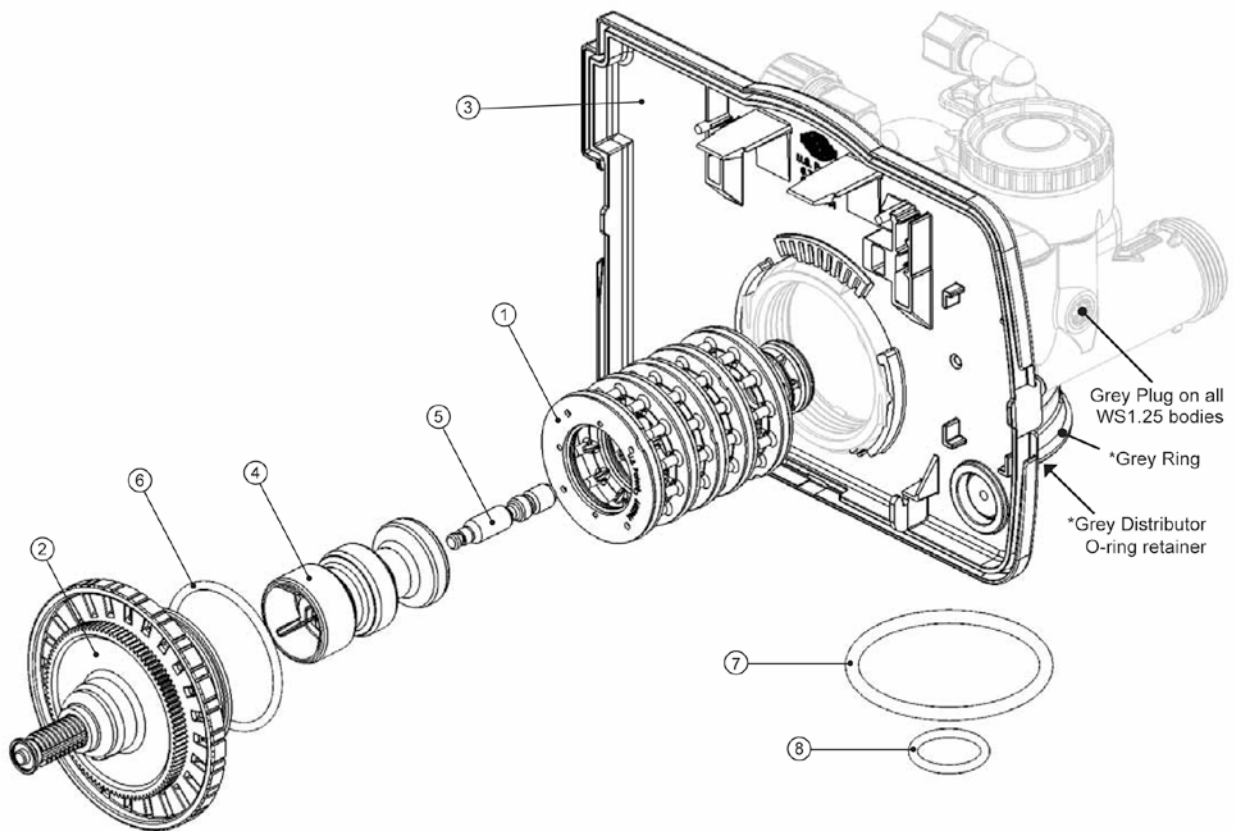

\*Only for valves that have a  
32mm Distributor Tube Opening

## Parts Breakdown

### Injector Housing Assembly

Drawing No.	Part No.	Description	Quantity
1	V3176	Injector Cap	1
2	V3152	O-Ring Injector Cap	1
3	V3177-01	Injector Screen	1
4	V3010-1A V3010-1B V3010-1C V3010-1D V3010-1E V3010-1F V3010-1G V3010-1H V3010-1I V3010-1J V3010-1K V3010-1Z	Injector Assembly – A Black Injector Assembly – B Brown Injector Assembly – C Violet Injector Assembly – D Red Injector Assembly – E White Injector Assembly – F Blue Injector Assembly – G Yellow Injector Assembly – H Green Injector Assembly – I Orange Injector Assembly – J Light Blue Injector Assembly – K Light Green Injector Assembly – Z Plug	1

*The size of your system will determine which injector assembly will be needed.*

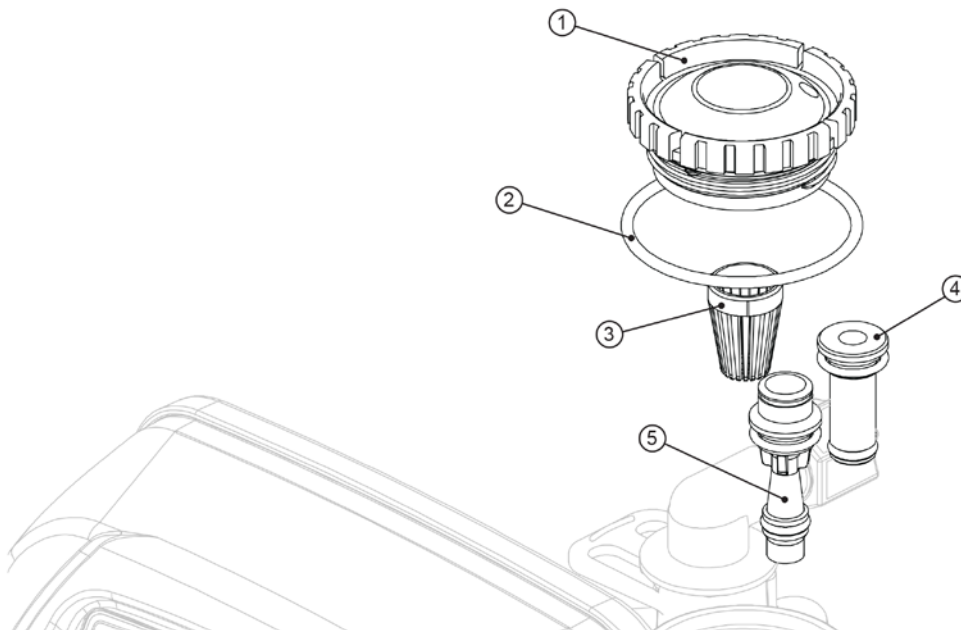

## Parts Breakdown

### Meter Assembly Breakdown

Drawing No.	Part No.	Description	Quantity
1	V3151	1" Retaining Nut	1
2	V3003	Meter Assembly (Turbine Included)	1
3	V3118-01	Turbine Assembly	1
4	V3105	Meter O-Ring	1
5	V3003-01	Meter Plug	1

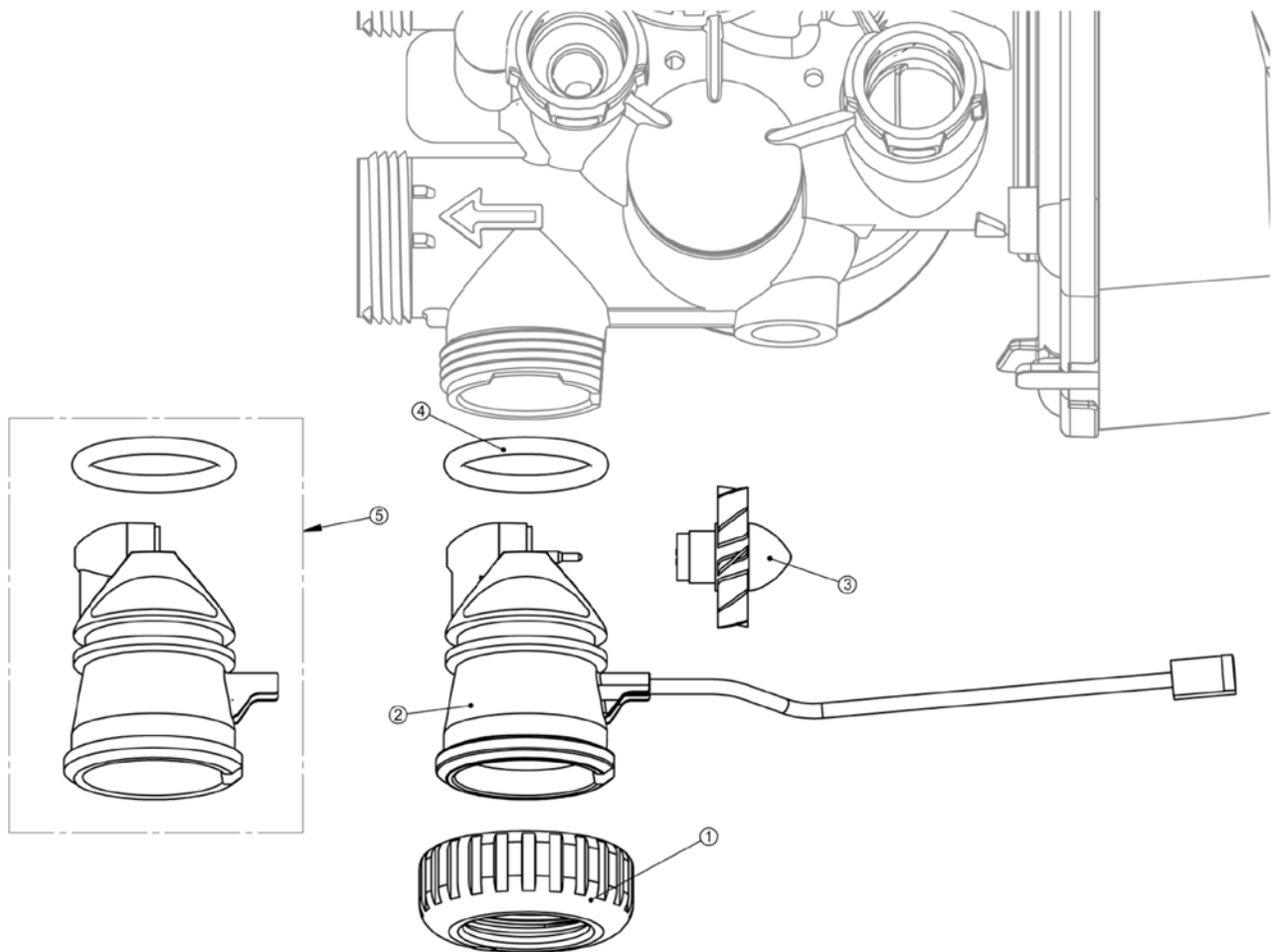



## Parts Breakdown

### Brine Elbow Refill Flow Assembly and Refill Port Plug

Drawing No.	Part No.	Description	Quantity
1	V3195-01	Refill Port Plug Assembly	Not normally used
2	H4615	Brine Elbow Locking Clip	1
3	JCP-P-6	Polytube Insert 3/8"	1
4	JCPG-6PBLK	Brine Elbow Nut 3/8"	1
5	V3330-01	Brine Elbow with Flow Control Retainer Assembly	1
6	V3163	Brine Elbow O-Ring	1
7	V3165-01	Brine Flow Control Retainer Assembly (0.5 GPM)	1

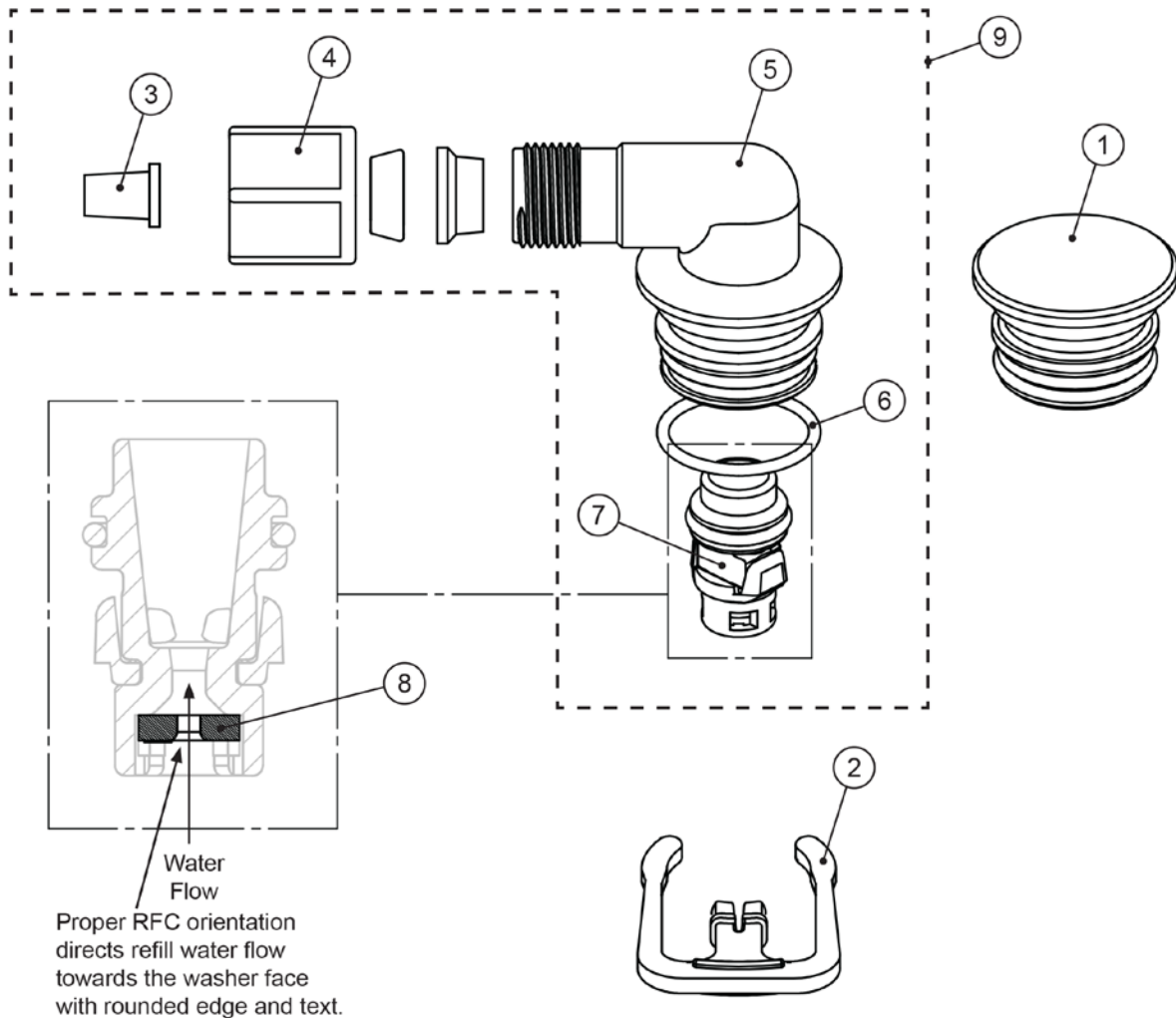

## Parts Breakdown

### Drain Line Assembly

Drawing No.	Part No.	Description	Quantity
1	H4615	Drain Elbow Locking Clip	1
2	PKP10TS8-BULK	Polytube Insert 5/8"	1
3	V3192	Drain Elbow Nut	1
4	V3158-01	Drain Elbow 3/4" Male NPT	1
5	V3163	Drain Elbow O-Ring	1
6	V3159-01	Drain Flow Control Retainer Assembly	1
7	V3162-XX	Drain Line Flow Control Button* *The size of your system will determine which flow control button is needed.	1

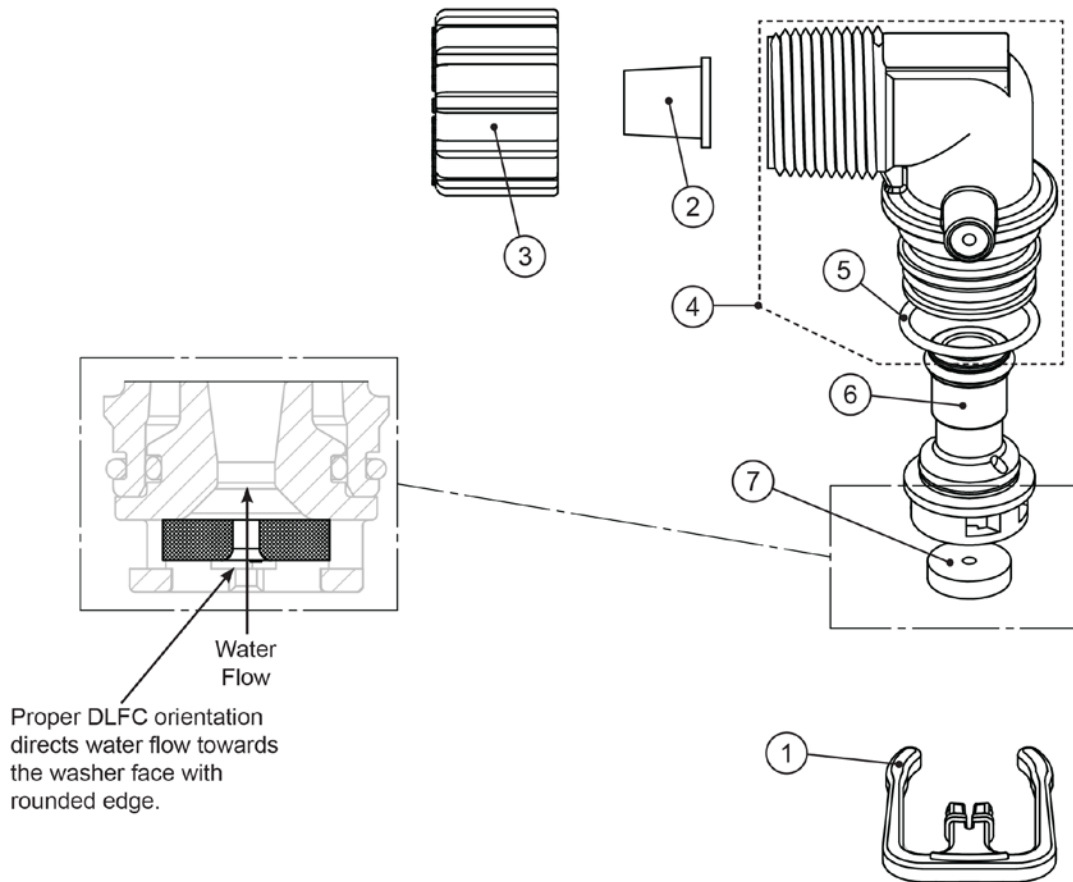

## Parts Breakdown

### 1" Drain Assembly

Drawing No.	Part No.	Description	Quantity
1	H4615	Elbow Locking Clip	1
2	V3008-02	Drain Footing Straight	1
3	V3166	Drain Footing Body	1
4	V3167	Drain Footing Adapter	1
5	V3163	O-Ring	1
6	V3150	Split Ring	1
7	V3151	1" Nut	1
8	V3105	O-Ring	1
9	V3190-XX	DLFC (Specify Size)	1

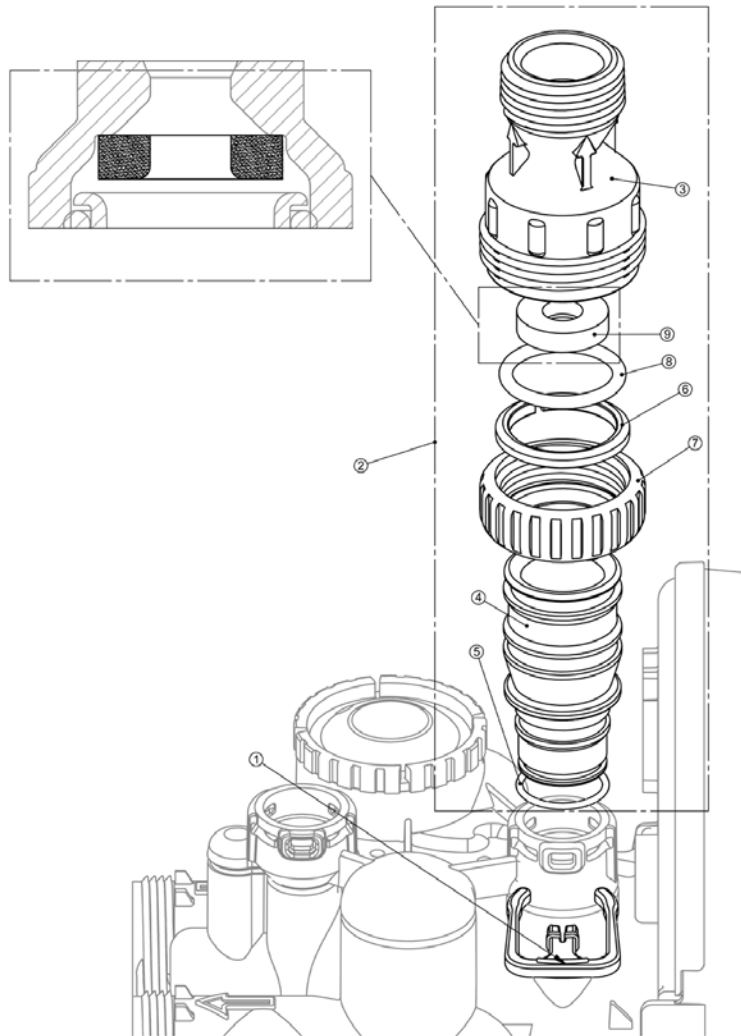

## Parts Breakdown

### Bypass Assembly Breakdown

Drawing No.	Part No.	Description	Quantity
1	V3151	1" Nut	2
2	V3150	Split Ring	2
3	V3105	O-Ring	2
4	V3145	1" Bypass Rotor	2
5	V3146	Bypass Cap	2
6	V3147	Bypass Handle	2
7	V3148	Bypass Rotor Seal Retainer	2
8	V3152	Bypass Cap O-Ring	2
9	V3155	Bypass Handle O-Ring	2
10	V3156	Bypass Rotor O-Ring	2

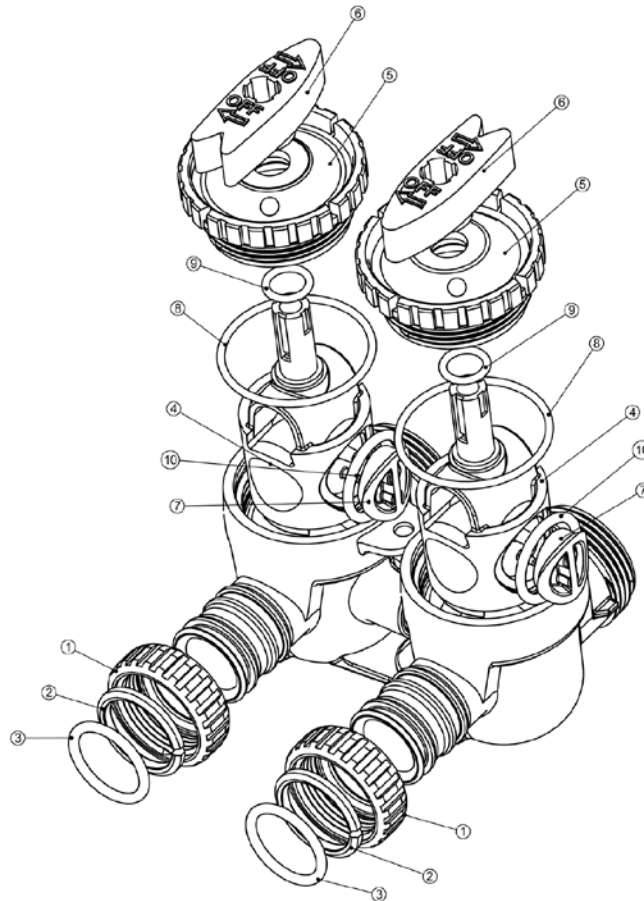

# Parts Breakdown

## Bypass Valve Operation

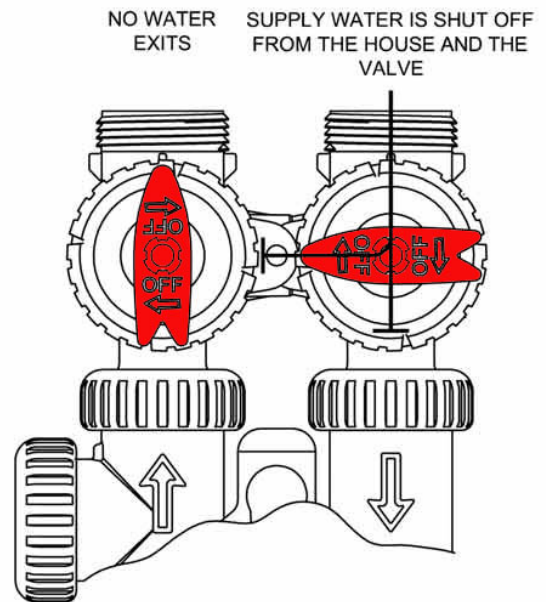
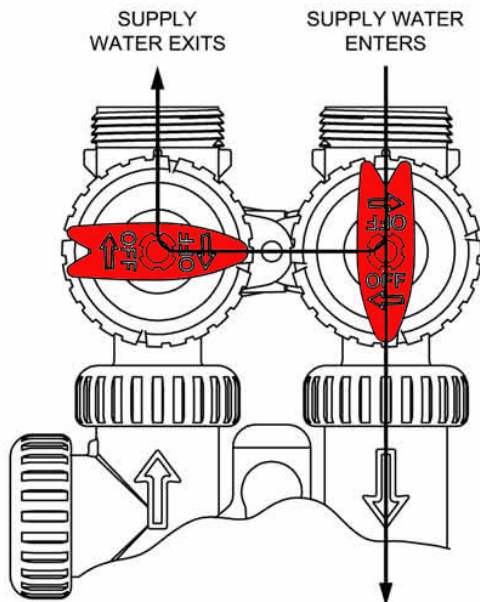
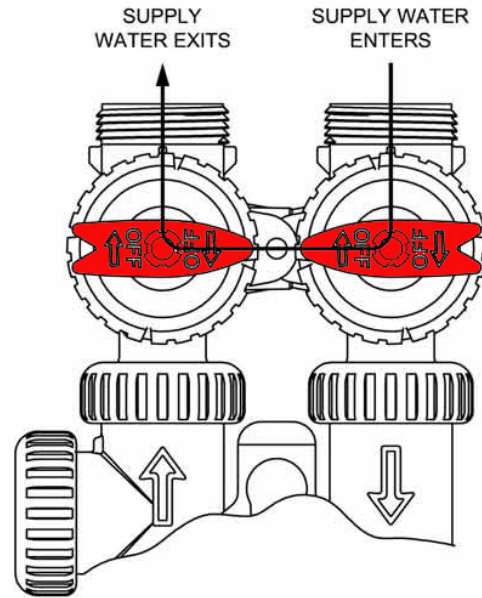
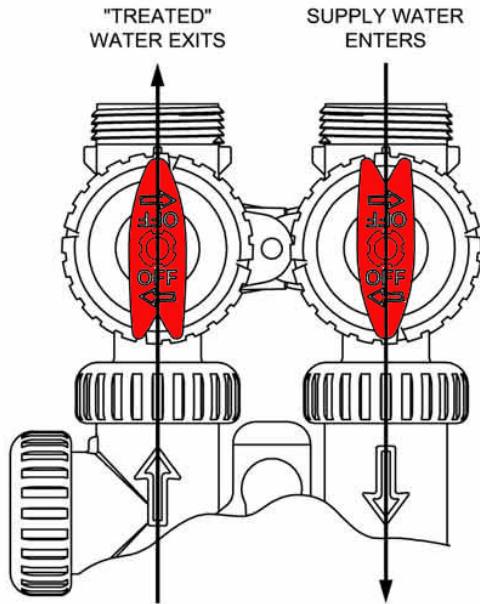

## Parts Breakdown

### Installation Fitting Assemblies

Drawing No.	Part No.	Description	Quantity
1	V3151	1" Nut	2
2	V3150	Split Ring	2
3	V3105	O-Ring	2
4	V3149	1" Fitting PVC Male NPT Elbow	2

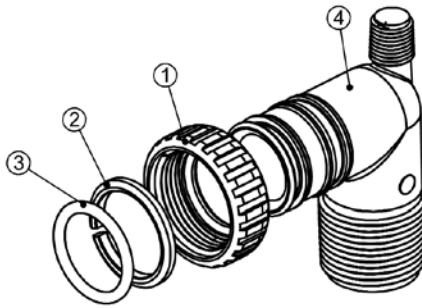

Drawing No.	Part No.	Description	Quantity
1	V3151	1" Nut	2
2	V3150	Split Ring	2
3	V3105	O-Ring	2
4	V3317	1.25" Plastic Male NPT	2

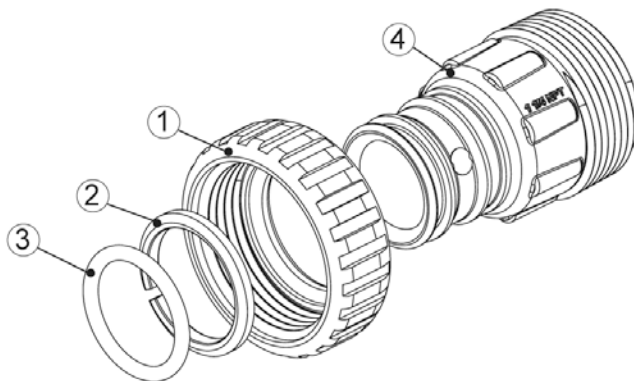

## Parts Breakdown

### Installation Fitting Assemblies

Drawing No.	Part No.	Description	Quantity
1	V3151	1" Nut	2
2	V3150	Split Ring	2
3	V3105	O-Ring	2
4	V3188	1" Fitting Brass Sweat	2

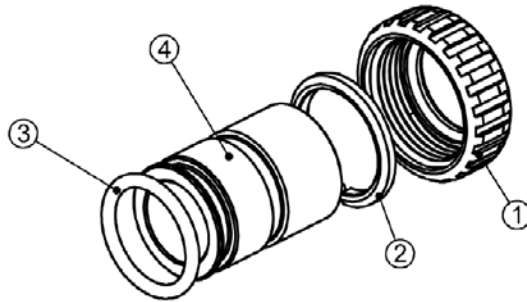

Drawing No.	Part No.	Description	Quantity
1	V3151	1" Nut	2
2	V3150	Split Ring	2
3	V3105	O-Ring	2
4	V3375	1.25" Fitting Brass Sweat	2

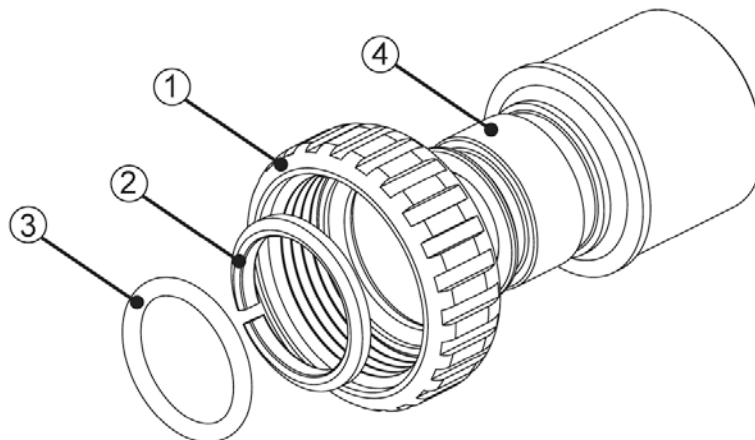

## Parts Breakdown

### Brine Tank Assembly

Drawing No.	Part No.	Description	Quantity
1		Deck Assembly (Specify Height)	1
2		Brine Tank (Specify Size)	1
3	HBVA474-8	474 Brine Valve Assembly	1
4	HBWS-XX	4" Brine Well (Specify Length)	1
5	HC-4	4" Brine Well Cap	1
6	HOF	Overflow Assembly	1

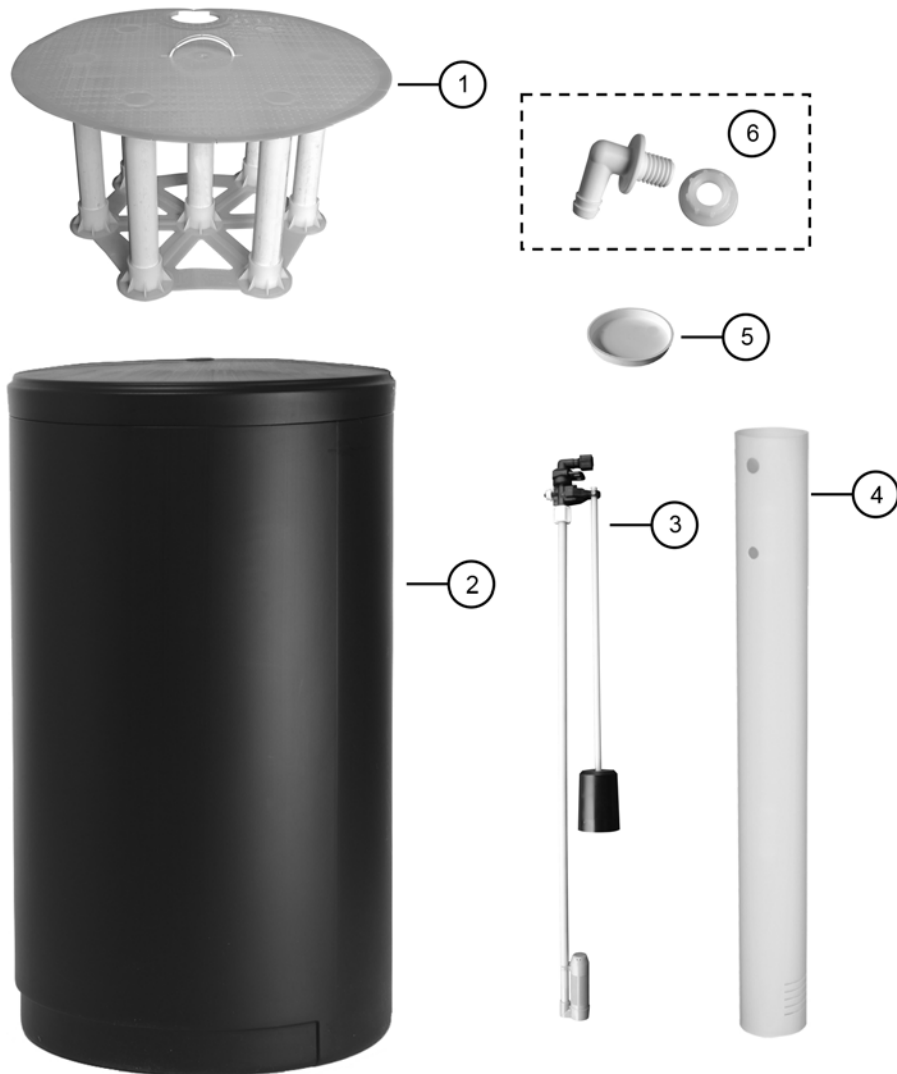



## System Specifications

### Mineral Tank Specifications

Grain Capacity	Mineral Tank	Gravel Lbs.	Resin Cu/Ft	Distributor Assembly
32,000	8x44	No Gravel	.9	D931-44
48,000	10x47	No Gravel	1.5	D931-54
60,000	12x52	No Gravel	2.0	D931-54
70,000	12x52	No Gravel	2.33	D931-54
80,000	13x54	No Gravel	2.66	D931-54
90,000	14 x 65	50	3.0	D931-72
120,000	16 x 65	50	4.0	D931-72
150,000	18 x 65	100	5.0	DHLBA-18
180,000	21 x 62	100	6.0	DHLBA-18
210,000	21 x 62	100	7.0	DHLBA-18

### Brine Tank Specifications

Grain Capacity	Brine Tank	Deck Height (in.)	Brine Float Valve	Brine Well
32,000	18 x 33	5	HBVA474-6	HBW-30S
48,000	18 x 40	5	HBVA474-6	HBW-36S
60,000	18 x 40	5	HBVA474-6	HBW-36S
70,000	18 x 40	5	HBVA474-6	HBW-36S
80,000	18 x 40	5	HBVA474-6	HBW-36S
90,000	24 x 41	NO DECK	HBVA474-6	HBW-36S
120,000	24 x 41	6	HBVA-474-6	HBW-36S
150,000	24 x 50	8	HBVA-474-8	HBWC-46S
180,000	24 x 50	10	HBVA-474-8	HBWC-46S
210,000	24 x 50	12	HBVA-474-8	HBWC-46S

## System Specifications

### Control Valve Specifications

<b>Grain Capacity</b>	<b>Injector Size</b>	<b>Drain Line Flow Control GPM</b>	<b>Brine Line Flow Control GPM</b>	<b>Brine Refill Time Min.</b>
32,000	D (RED)	1.3	0.5	6 MIN 11 SEC
48,000	E (WHITE)	1.7	0.5	7 MIN 52 SEC
60,000	E (WHITE)	2.7	0.5	13 MIN 20 SEC
70,000	E (WHITE)	2.7	0.5	15 MIN 20 SEC
80,000	F (BLUE)	3.2	0.5	17 MIN 20 SEC
90,000	G (YELLOW)	4.2	0.5	20 MIN 00 SEC
120,000	H (GREEN)	5.3	0.5	26 MIN 40 SEC
150,000	I (ORANGE)	7.5	0.5	33 MIN 20 SEC
180,000	J (LIGHT BLUE)	10	0.5	40 MIN 00 SEC
210,000	K (LIGHT GREEN)	10	0.5	46 MIN 40 SEC

# Service Instructions

### Service Instructions

#### Drive Assembly - Disassembly and Inspection:

Remove the valve cover to access the drive assembly.

The drive bracket must be removed to access the drive cap assembly and pistons or the drive gear cover. It is not necessary to remove the circuit board from the drive bracket to remove the drive bracket. Press and hold the REGEN button (approx. 6 seconds) until the unit begins a regeneration cycle (this action will ensure that the threaded piston rod will not interfere with the removal of the drive bracket and circuit board assembly.) Disconnect the power source plug (4 pin, black cable) from the circuit board prior to disconnecting any other plugs from the circuit board. Disconnect the water meter plug (3 pin, grey cable), located on the far right side of the circuit board. Unweave the wires from the side holders. Two tabs on the top of the drive back plate hold the drive bracket in place. Simultaneously lift the two tabs and gently ease the top of the drive bracket towards your body. The lower edge of the drive bracket has two notches that rest on the drive back plate. Lift up and outward on the drive bracket to disengage the notches.

To inspect the drive reduction gears, the drive gear cover needs to be removed. The drive gear cover is held in place on the drive bracket by three clips. The largest of the three clips is always orientated to the bottom of the drive bracket. With the circuit board facing up, push in and down on the large clip on the drive gear cover. Handle the cover and the gears carefully so that the gears do not fall off of the pegs in the cover. Replace broken or damaged drive gears. Do not lubricate any of the gears. Avoid getting any foreign matter on the reflective coating because dirt or oils may interfere with pulse counting.

The drive bracket does not need to be removed from the drive plate if the motor needs to be removed. To remove the motor, disconnect the power and motor plugs from the jacks on the circuit board. Move the spring clip loop to the right and hold. Rotate the motor at least a 1/4 turn in either direction before gently pulling on the wire connectors to remove the motor. Pulling directly on the wires without rotating the motor may break the wires off the motor. Visually inspect the motor for free spinning and remaining brush life (visible through slots on the size of the motor). Check the pinion gear for endplay. If the pinion gear is pushed tight against the motor housing, eliminating endplay, slide it away from the housing so the end of the shaft is flush with the end of the gear.

The circuit board can be removed separately from the drive bracket but it is not recommended. Do not attempt to remove the display panel from the circuit board. Handle the board by the edges. To remove the circuit board from the drive bracket, unplug the power, water meter and motor plugs from the circuit board. Lift the middle latch along the top of the drive bracket while pulling outward on the top of the circuit board. The drive bracket has two plastic pins that fit into the holes on the lower edge of the circuit board. Once the circuit board is tilted about 45° from the drive bracket it can be lifted off of these pins. To reinstall the circuit board, position the lower edge of the circuit board so that the holes in the circuit board line up with the plastic pins. Push the top of the circuit board towards the valve until it snaps under the middle latch, weave the power and water meter wires into the holders and reconnect the motor, water meter and power plugs.

### Drive Assembly - Reassembly:

If the drive gear cover was removed, reinstall it with the large clip orientated towards the bottom. If all three clips are outside of the gear shroud on the drive bracket the drive gear cover slips easily into place.

To reinstall the drive bracket, seat the bottom of the drive bracket so the notches are engaged at the bottom of the drive back plate. Push the top of the drive bracket towards the two latches. The drive bracket may have to be lifted slightly to let the threaded piston rod pass through the hole in the drive bracket. Maintain a slight engaging force on top of the drive bracket while deflecting the bracket slightly to the left by pressing on the side of the upper right corner. This helps the drive gears mesh with the drive cap assembly. The drive bracket is properly seated when it snaps under the latches on the drive back plate. If resistance is felt before latching, then notches are not fully engaged, the piston rod is not in hole, the wires are jammed between the drive bracket and drive back plate, or the gear is not engaging the drive cap assembly. Replace the motor if necessary. Do not lubricate the motor or the gears. To reinstall the motor, move the spring clip loop to the right and hold. Gently turn the motor while inserting so that the gear on the motor meshes with the gears under the drive gear cover. Release the spring clip loop and continue to rotate the motor until the motor housing engages the small plastic bulge inside the drive bracket motor retainer. Reconnect the motor plug to the two-pronged jack on the lower left hand side of the circuit board. If the motor will not easily engage with the drive gear when reinstalling, lift and slightly rotate the motor before reinserting. Reconnect the power plug.

Replace the valve cover. After completing any valve maintenance, press and hold NEXT and REGEN buttons for 3 seconds. This resets the electronics and establishes the service piston position. The display should flash all wording, then flash the software version and then reset the valve to the service position.

### Drive Cap Assembly

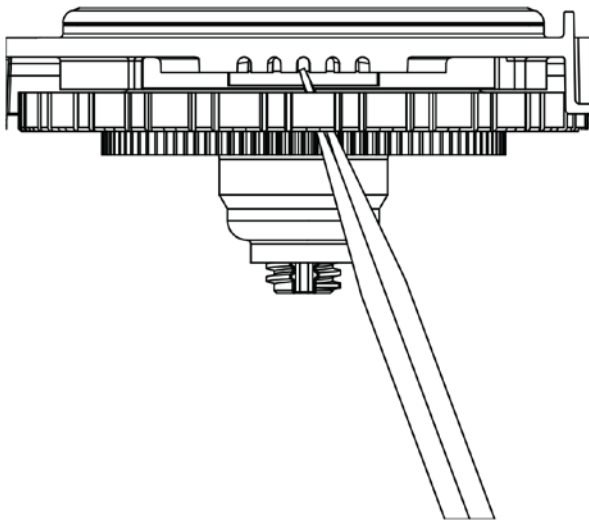

The drive assembly must be removed to access the drive cap assembly. The drive cap assembly must be removed to access the pistons. The drive cap assembly is threaded into the control valve body and sealed with an O-ring. To remove the drive cap assembly use the special plastic wrench (part number) or insert a  $\frac{1}{4}$ " to  $\frac{1}{2}$ " flat blade screwdriver into one of the slots around the top two inches of the drive cap assembly so it engages the notches molded into the drive back plate around the top two inches of the piston cavity. The notches are visible through the holes. Lever the screwdriver so the drive cap assembly turns counterclockwise. Once loosened unscrew the drive cap assembly by hand and pull straight out.

The drive cap assembly contains the drive cap, the main drive gear, drive cap spline, piston rod and various other parts that should not be disassembled in the field. Visually inspect the drive cap for damage and free operation of the gear and threaded rod. The only replaceable part on the drive cap assembly is the O-ring.

### **Main Piston and Brine Piston - Disassembly and Inspection**

Attached to the drive cap assembly is the main piston and the brine piston. The brine piston (the small diameter one behind the main piston) is removed from the main piston by unsnapping it from its disassembly latch. To remove the main piston, fully extend the piston rod and then unsnap the main piston from its latch by pressing on the side with the number. Chemically clean the piston in dilute sodium bisulfite or vinegar, or replace them. The main piston is teflon coated. If the teflon coating is damaged, replace the main piston.

### **Main Piston and Brine Piston - Reassembly**

Reattach the main piston to the drive cap assembly. Reattach the brine piston to the main piston. Reinsert the drive cap assembly and piston into the seal and spacer stack assembly insert the four screws and tighten the drive cap assembly. Make certain that the main drive gear still turns freely. Rotate the main drive gear counter-clockwise until it stops (*this action will ensure that the threaded piston rod will not interfere with the reattachment of the drive bracket and circuit board assembly.*) Reattach the drive back plate by sliding it over the two tabs and rotating clockwise until the drive back plate “clicks” into place

Reattach the drive bracket and circuit board assembly to the control valve and connect all plugs. After completing any valve maintenance, press and hold NEXT and REGEN buttons for 3 seconds. This resets the electronics and establishes the service piston position. The display should flash all wording, then flash the software version and then reset the valve to the service position.

### **Seal and Spacer Stack Assembly - Disassembly and Inspection**

To access the spacer stack assembly remove the drive assembly, drive cap assembly and piston. The spacer stack assembly can then be pulled straight out. Inspect the black O-rings and inner seals for wear or damage, replace the entire stack if necessary. Do not disassemble the stack.

The spacer stack assembly may be chemically cleaned (dilute sodium bisulfite or vinegar) or wiped with a soft cloth.

### **Seal and Spacer Stack Assembly - Reassembly**

The seal and spacer stack assembly can be pushed into the control valve body bore by hand. The control valve body bore interior can be lubricated with silicone to allow for easy insertion of the entire stack.

Reattach the drive cap assembly and piston(s) and the drive assembly.

After completing any valve maintenance, press and hold NEXT and REGEN buttons for 3 seconds. This resets the electronics and establishes the service piston position. The display should flash all wording, then flash the software version and then reset the valve to the service position.

### **Injector Cap, Screen, and Injector - Disassembly and Inspection**

Unscrew the injector cap and lift off. Loosen the cap with special plastic wrench (part number) or pliers if necessary. Attached to the injector cap is a screen. Remove the screen and clean if fouled. The injector can be pried out with a small screwdriver. The injector consists of a throat and nozzle. Chemically clean the injector with vinegar or sodium bisulfite. The holes can be blown out with air. Both pieces have small diameter wholes that control the flow rates of water to ensure that the proper concentration of regenerant is used. Sharp objects, which can score the plastic, should not be used to clean the injector.

### **Injector Cap, Screen and Injector - Reassembly**

Press injector into its borehole and press until seated all the way down. Replace the injector cap.

### **Refill Flow Control Assembly - Disassembly and Inspection**

To clean or replace the refill flow control, remove the nut and then pull the fitting straight out.

Remove the flow control retainer from the injector housing.

Chemically clean the flow control or the flow control retainer using dilute sodium bisulfite or vinegar. Do not clean with abrasive methods. If necessary, replace the flow control, O-ring on the flow control retainer, or the O-ring on the fitting.

### **Refill Flow Control Assembly - Reassembly**

Insert the flow control into its seat, confirming correct flow control orientation. Place the flow control retainer into the injector housing and reassemble the fitting (*see diagram in the exploded view section*).





# Troubleshooting the Control Valve



## Control Valve Trouble Shooting

Problem	Possible Cause	Solution
No display on Control Valve Circuit Board	No power at electrical outlet	Repair outlet or use working outlet
	Control Valve Power Cord not plugged onto Control Valve Circuit Board	Make sure Control Valve Power Cord is connected securely at both ends
	Improper power supply	Verify proper voltage is being delivered to Circuit Board
	Defective Circuit Board	Replace Circuit Board
Control Valve Circuit Board does not display correct time of day	Control Valve Power Cord plugged into electric outlet controlled by light switch	Use uninterrupted outlet
	Tripped Breaker Switch and/or tripped GFI	Reset Breaker Switch and/ or GFI switch
	Power outage	Reset time of day. If Circuit Board has battery back up present, the battery may be depleted. Replace if necessary.
	Defective Circuit Board	Replace Circuit Board
Display does not indicate that water is flowing. The word "Softening" flashes on the display when water is being used	Bypass valve in bypass position	Turn Bypass Handles to place Bypass in service position
	Meter is not connected to meter connection on Circuit Board or is not connected securely	Connect Meter to three-pin connection labeled METER on Circuit Board. Remove and reconnect to ensure proper connection
	Restricted/ stalled Meter Turbine	Remove Meter and check for rotation or foreign material
	Defective Meter	Replace Meter
	Defective Circuit Board	Replace Circuit Board
Time of day flashes on and off	Power outage	Reset time of day. If Circuit Board has battery back up present, the Battery may be depleted. Replace if necessary.
Control valve does not regenerate automatically when the REGEN button is depressed and held.	Broken Drive Gear or Drive Cap Assembly	Replace Drive Gear or Drive Cap Assembly
	Broken Piston Rod	Replace Piston Rod
	Defective PC Board	Defective PC Board
Control valve does not regenerate automatically but <b>does</b> when the REGEN button is depressed and held.	Bypass Valve in bypass position	Turn Bypass Handles to place Bypass in service position
	Meter is not connected to meter connection on Circuit Board or is not connected securely	Connect Meter to three pin connection labeled METER on Circuit Board. Remove and reconnect to ensure proper connection
	Restricted/ stalled Meter Turbine	Remove Meter and check for rotation or foreign material
	Incorrect programming	Check for programming error
	Defective Meter	Replace Meter
	Defective Circuit Board	Replace Circuit Board

## Control Valve Trouble Shooting

Problem	Possible Cause	Solution
Hard or untreated water is being delivered	Bypass Valve is open or faulty	Fully close Bypass Valve or replace. Also check for multiple bypasses
	Media is exhausted due to high water usage	Check program settings or diagnostics for abnormal water usage
	Meter not registering	Remove Meter and check for rotation or foreign material
	Water quality fluctuation	Test water and adjust program values accordingly
	No Salt or low level of Salt in Brine Tank	Add proper type of salt to Brine Tank
	Control Valve fails to draw in brine	Refer to Trouble Shooting Guide number 12
	Insufficient brine level in Brine Tank	Check refill setting in programming. Check Refill Flow Control for restrictions or debris and clean or replace
	Damaged Seal and Spacer Stack Assembly	Replace Seal and Spacer Stack Assembly
	Control valve body type and piston type mix matched	Verify proper control valve body type and piston type match
	Fouled media bed	Replace media bed
System uses too much salt	Improper refill setting	Check refill setting
	Improper program settings	Check program setting to make sure they are specific to the water quality and application needs
	Control valve regenerates frequently	Check for leaking fixtures that may be exhausting capacity or system is undersized
	Slow drip from brine refill tubing. Float Valve is not designed to shut off a drip	Replace Seal and Spacer Stack Assembly
Residual salt in service lines	Low water pressure	Check incoming water pressure. Water pressure must remain at minimum of 40 psi
	Incorrect injector size	Replace Injector with correct size for the application. Refer to System Specification for the correct size
	Restricted drain line	Check drain line for restrictions or debris and clean
Excessive water in Brine Tank	Improper program settings	Check refill setting
	Plugged Injector	Remove Injector and clean or replace
	Drive cap assembly not tightened in properly	Re-tighten the drive cap assembly
	Damaged Seal and Spacer Stack Assembly	Replace Seal and Spacer Stack Assembly
	Restricted or kinked drain line	Check drain line for restrictions or debris and or un-kink drain line
	Plugged backwash flow controller	Remove backwash flow controller and clean or replace
	Missing Refill Flow Controller	Replace Refill Flow Controller

## Control Valve Trouble Shooting

Problem	Possible Cause	Solution
Control Valve fails to draw brine	Injector is plugged	Remove Injector and clean or replace
	Faulty Brine Piston	Replace Brine Piston
	Brine line tubing connection leak	Inspect Tubing and Fittings for air leak
	Drain line restriction or debris can cause excess back pressure on Injector	Inspect drain line and clean to correct restriction
	Drain line too long or elevated too high	Shorten length and or height
	Low water pressure	Check incoming water pressure. Water pressure must remain at minimum of 40 psi
Water running to drain	Power outage during regeneration	Upon power being restored Control Valve will finish the remaining regeneration time. Reset time of day.
	Damaged Seal and Spacer Stack Assembly	Replace Seal and Spacer Stack Assembly
	Piston assembly failure	Replace Piston Assembly
	Drive Cap Assembly not tightened in properly	Re-tighten the Drive Cap Assembly
Err - 1001 = Control unable to sense motor movement	Motor not inserted full to engage pinion, motor wires broken or disconnected	Disconnect power, make sure motor is fully engaged, check for broken wires, make sure two pin connector on motor is connected to the two pin connection on the Circuit Board labeled MOTOR. Press NEXT and REGEN buttons at the same time for 3 seconds to resynchronize software with piston.
	Circuit Board not properly snapped into drive bracket	Properly snap Circuit Board into drive bracket and then Press NEXT and REGEN buttons at the same time for 3 seconds to resynchronize software with piston.
	Missing reduction gears	Replace missing gears
Err - 1002 = Control valve motor ran too short and was unable to find the next cycle position and stalled	Foreign material is lodged in control valve	Open up Control Valve and pull out piston assembly and Seal and Spacer Stack Assembly for inspection. Press NEXT and REGEN buttons at the same time for 3 seconds to resynchronize software with piston.
	Mechanical binding	Check Piston and Seal and Spacer Stack Assembly, check Reduction Gears, check Drive Bracket and Main Drive Gear Interface. Press NEXT and REGEN buttons at the same time for 3 seconds to resynchronize software with piston.
	Main Drive Gear too tight	Loosen Main Drive Gear. Press NEXT and REGEN buttons at the same time for 3 seconds to resynchronize software with piston.
	Improper voltage being delivered to Circuit Board	Verify that proper voltage is being supplied. Press NEXT and REGEN buttons at the same time for 3 seconds to resynchronize software with piston.

## Control Valve Trouble Shooting

Problem	Possible Cause	Solution
Err - 1003 = Control valve motor ran too long and was unable to find the next cycle position	Motor failure during a regeneration	Check motor connections then Press NEXT and REGEN buttons at the same time for 3 seconds to resynchronize software with piston.
	Foreign matter built up on Piston and Seal and Spacer Stack Assemblies creating friction and drag enough to time out Motor	Replace Piston and Seal and Spacer Stack Assemblies. Press NEXT and REGEN buttons at the same time for 3 seconds to resynchronize software with piston.
	Drive Bracket not snapped in properly and out enough that reduction gears and drive gear do not interface	Snap Drive Bracket in properly then Press NEXT and REGEN buttons at the same time for 3 seconds to resynchronize software with piston.
Err - 1004 = Control valve motor ran too long and timed out trying to reach home position	Drive Bracket not snapped in properly and out enough that reduction gears and drive gear do not interface	Snap Drive Bracket in properly then Press NEXT and REGEN buttons at the same time for 3 seconds to resynchronize software with piston.

### ***Manufacturer's Limited Warranty***

Pacific Water Inc. ("Manufacturer") warrants to the original owner that its Water Conditioning Equipment will be free from defects in material and workmanship under normal use and service for a period of five (5) years from the date of installation, when installed and operated within recommended parameters. No warranty is made with respect to defects not reported to Manufacturer within the warranty period and/or defects or damages due to neglect, misuse, alterations, accident, misapplication, physical damage, or damage caused by fire, floods, acts of God, freezing or hot water or similar causes. Manufacturer's obligation to the owner of this equipment under this Limited Warranty shall be limited, at its option, to replacement or repair of this Water Conditioning Equipment.

To obtain warranty service mail or ship the defective parts freight prepaid to the Manufacturer's place of business. Manufacturer will, at its option, repair or replace the defective components at its expense and return parts freight collect.

Manufacturer gives this warranty to the owner in lieu of all other warranties, express or implied, including without limitation any implied warranties of merchantability or fitness for a particular purpose and hereby expressly disclaims all other such warranties. Manufacturer's liability hereunder shall not exceed the cost of the product. Under no circumstances will Manufacturer be liable for any incidental or consequential damages or for any other loss, damage or expense of any kind, including loss of profits, arising in connection with the installation or use or inability to use this product.

To obtain warranty service contact:

Pacific Water Inc.  
200 W. Haven Ave.  
Salt Lake City, Utah 84115

Phone 801-485-6510  
Fax 801-467-4117  
Email [sales@pacificwaterinc.com](mailto:sales@pacificwaterinc.com)

